



BP Lifts
By Barker Products
1310 Miller Road, Greenville, SC 29607



Model BPHB27-4539 Lift

Part # BU19839



- Dependable Smooth Acting 27K Helical Rotary Actuator
- Splined Shafts To Eliminate Arm Movement And Wear
- 50 Degree Dump Angle
- No Grease Points
- EZ Bolt On Kit Standard
- Meets ANSI Z245 Type B Specs
- Lifts All Standard American 2 Bar Carts
- Liftplate Arc Motion Makes Cart Attachment Fast And Easy On Unlevel Highway Conditions
- Double Wide Mounting Plate Available. Increases Hopper Height To Decrease Packing Cycles
- 39 to 43 Inch Mounting Height
- 23 1/8 to 25 1/8 Inch Ground Clearance
- Use on Rear Loaders with or without kick bars
- Limit Hydraulic Input pressure to 1700 PSI

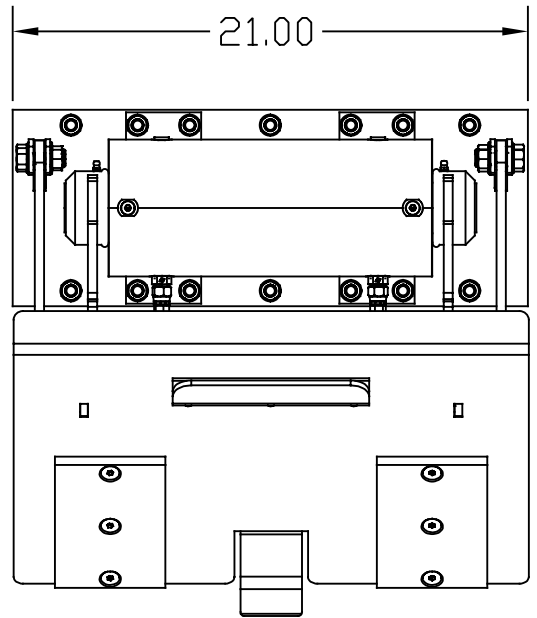
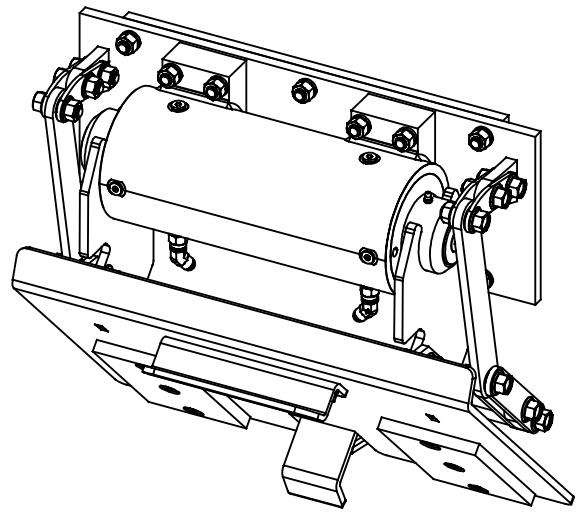
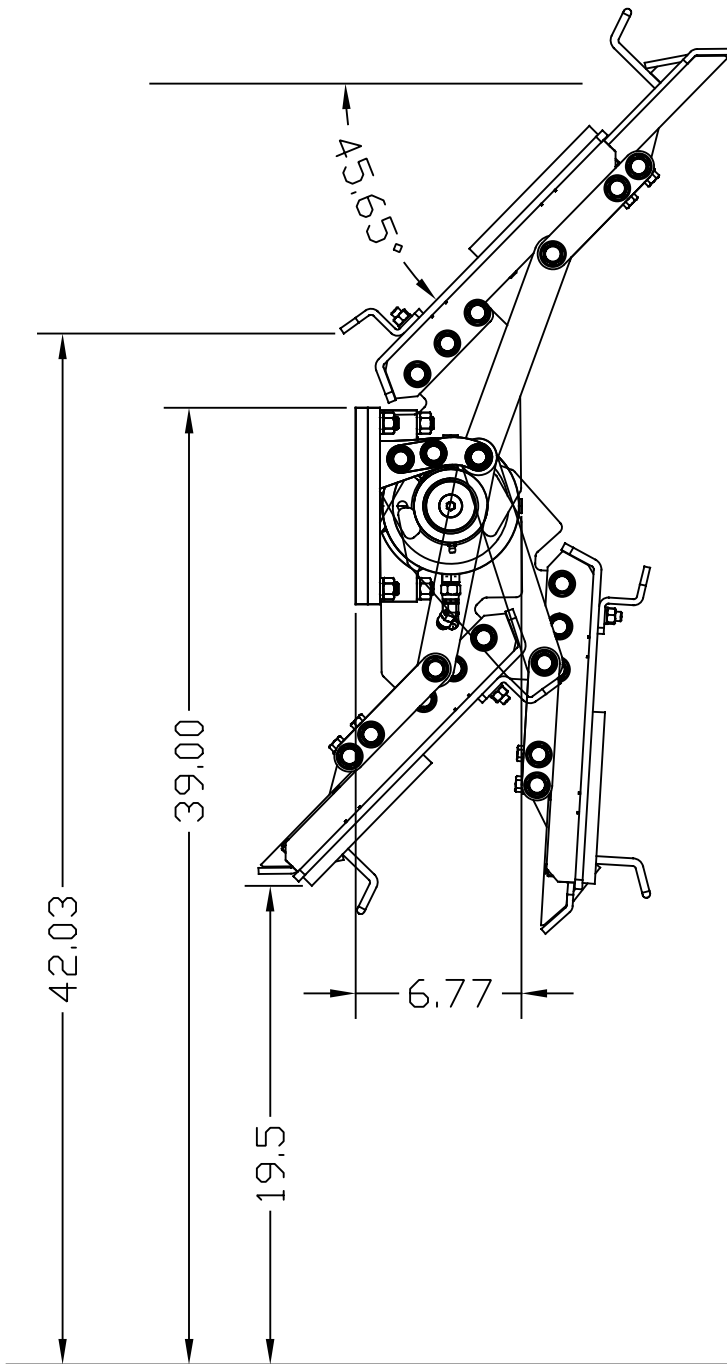

GROUND LEVEL



BARKER PRODUCTS
1310 MILLER ROAD
GREENVILLE, SC
29607

DRAWN BY: R WYMAN

DATE: 7/6/2023

MATERIAL: NOTED

DO NOT SCALE
DRAWING
UNLESS OTHERWISE SPECIFIED
DIMENSIONS ARE IN INCHES
TOLERANCES:
FRACTIONAL $\pm 1/32$
ANGULAR: MACH $\pm 1^\circ$ BEND $\pm 1^\circ$
TWO PLACE DECIMAL ± 0.010
THREE PLACE DECIMAL ± 0.005

HB27-4539 LIFT
BW18400 ACTUATOR

DRAWING NO
BU19839

REV
00

SCALE: 1:8

WEIGHT: 216.310 #

SHEET 1 OF 1

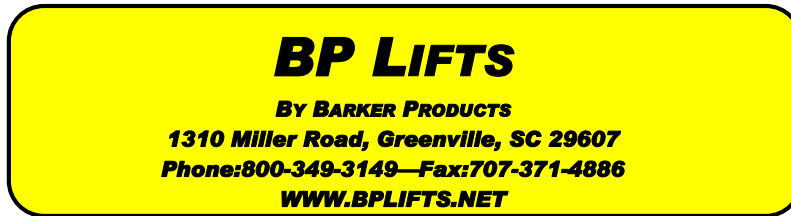

Lift Unit Installation

1. Truck must be empty, clean and parked on a level surface before installation is started.
2. Remove all bumpers and running boards that will interfere with the location of the lift units. Relocate lower mounted tail lights as needed.
3. Measure and mark the centerline of the truck hopper. The centerline of the unit or units should be a minimum of 17" from the hopper centerline.
4. Hand valves should be mounted on the side of the hopper at the most convenient height for the operator and clear of the packer controls.
5. The top of the unit mounting plate should be tack welded in place at the height recommended on the envelope dimension sheet of the unit.
CAUTION: SEE NOTE BELOW PICTURE
6. All dimensions should be approved by the customer before final welding.
7. If the mounting plate extends more than 2" above the hopper, a brace should be added.

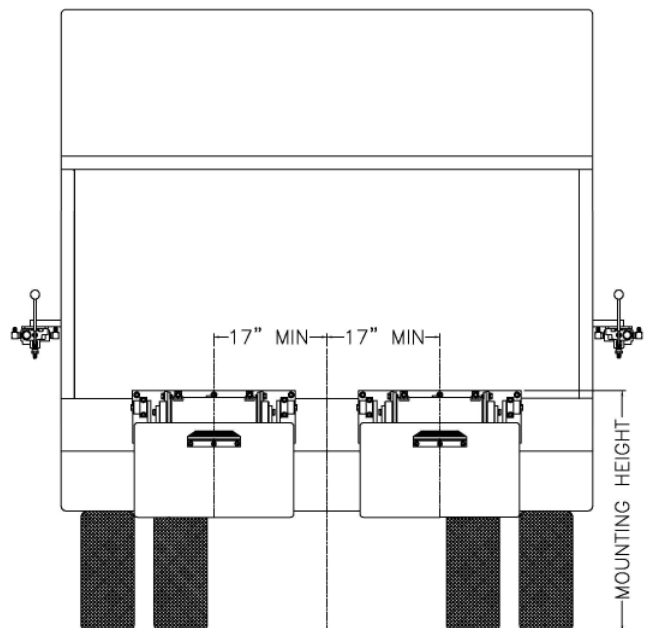

Mounting heights and locations are recommendations only. It is the responsibility of the installer to insure that the customer is satisfied with the height. Barker Products recommends that after the units are tacked in place, try the units with the can or cans the customer uses. The customer should approve your mount before final welding.

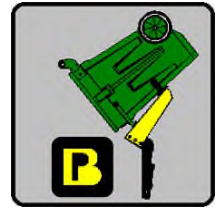
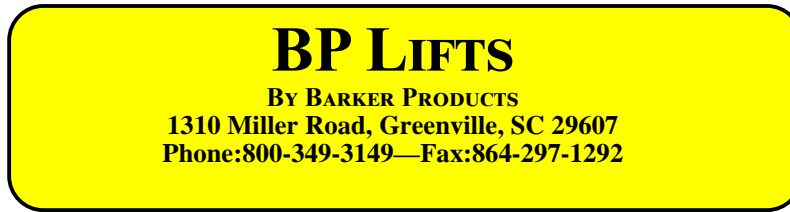

BPH27-198XX SERIES LIFT UNIT WARRANTY

Barker Products warrants each new dump unit to be free of defects in material and workmanship under normal use and service for a period of 1 year or 2000 hours of operation, whichever comes first, from the date of delivery.

This warranty excludes any obligations by BARKER PRODUCTS for the cost of down time. BARKER PRODUCTS will not warranty any dump unit which has been subject to misuse, neglect, alteration, or damaged by an accident.

On any work not performed by BARKER PRODUCTS or it's representative, the customer will be responsible for freight charges on all parts shipped under warranty. Parts will be invoiced at time of shipment. Defective parts must be returned to BARKER PRODUCTS within 30 days. If the part is determined to be defective the customer will be credited for the original invoice.

Customer warranty labor charges must be approved by BARKER PRODUCTS in advance. If not contacted for approval, BARKER PRODUCTS will not be liable for the warranty labor charge.

Limit hydraulic input pressure to 2000PSI

ITEM NO.	PART NUMBER	DESCRIPTION	QTY.
1	BW19739	LEFT LIFT ARM	1
2	BW18005	SPLINE CAP HB25	2
3	BW19321	SLIDE LINK	2
4	BWA19290	LIFT PLATE SUB ASSY	1
5	BWA19280	SLIDE SUB ASSY	1
6	BW99108	1/2" SPHERICAL BEARING	2
7	BW19740	RIGHT LIFT ARM	1
8	BWA19014	MAINFRAME SUB ASSY	1

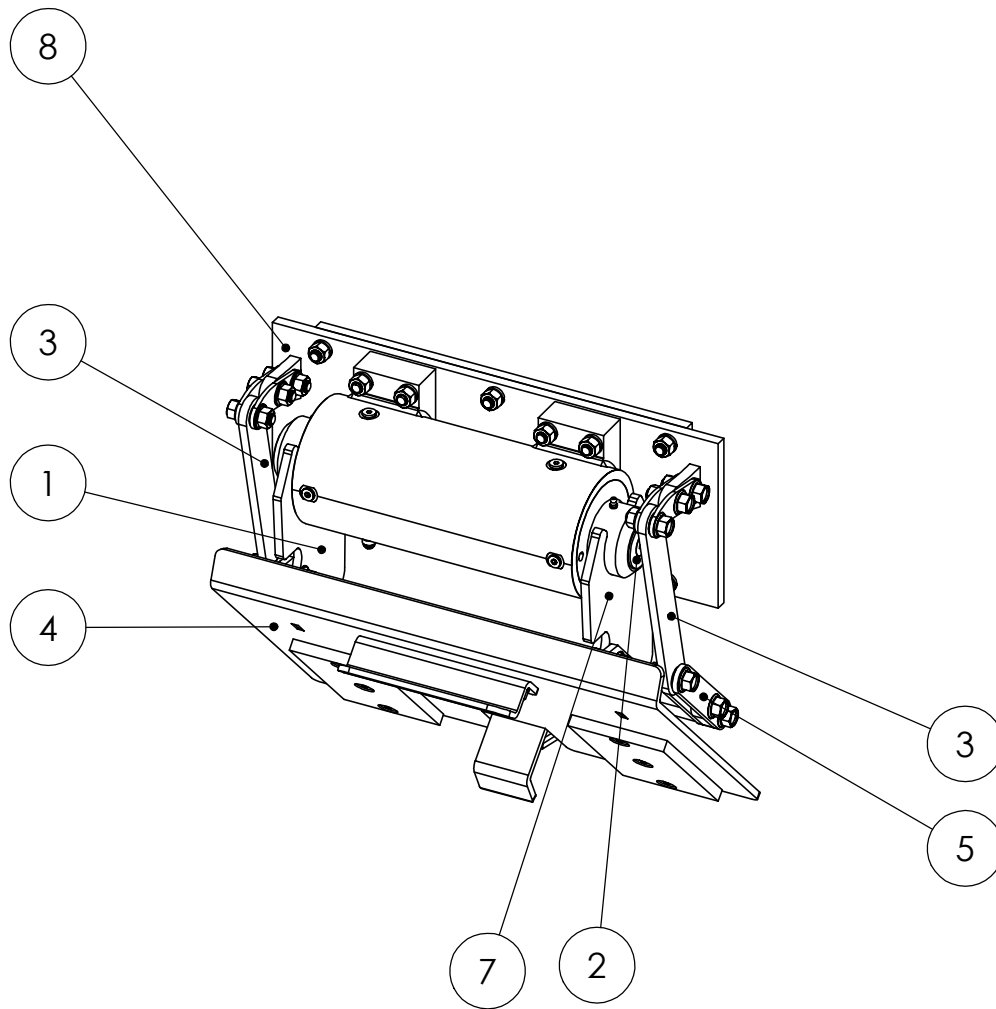

BARKER PRODUCTS
1310 MILLER ROAD
GREENVILLE, SC
29607

DRAWN BY: R WYMAN
DATE: 7/25/2023
MATERIAL: NOTED

DO NOT SCALE
DRAWING
UNLESS OTHERWISE SPECIFIED:
DIMENSIONS ARE IN INCHES
TOLERANCES:
FRACTIONAL ±1/32
ANGULAR: MACH ±1° BEND ±1°
TWO PLACE DECIMAL ±0.010
THREE PLACE DECIMAL ±0.005

HB27-4539 LIFT
BW18400 ACTUATOR

DRAWING NO
BU19839

REV
00

SCALE: 1:8 WEIGHT: 215.805 # SHEET 1 OF 1

ITEM NO.	PART NUMBER	DESCRIPTION	QTY.
1	BW19014	MAINFRAME	1
2	BW17525	MOUNT PLATE - N	1
3	BW07140	PLATE STUD	6
4	BW07105	ACTUATOR MOUNT STUD	8
5	BW18400	ACTUATOR	1
6	XEB081000	1/2 LOCKWASHER	14
7	XDA082000	1/2-20 HEX NUT	14
8	BW18050	SL PIVOT CAP	4
9	XDH081300	1/2-13 FLANGED NUT	6
10	XAE081312	1/2-13 X 1 1/2 FLANGED HHCS	6
11	BW99108	1/2" SPHERICAL BEARING	2
12	BW18002	O-RING GREASE SEAL	2
13	BV00064	6T X 6S ORIFICE FITTING	1
14	BV00025	116 X 1/8 NPT ORIFICE PLUG	1
15	BR04842	6502-06-06 MJ-FJS 45 DEG	2
16	BR03830	6400-06-06 M TUBE TO O-RING	1

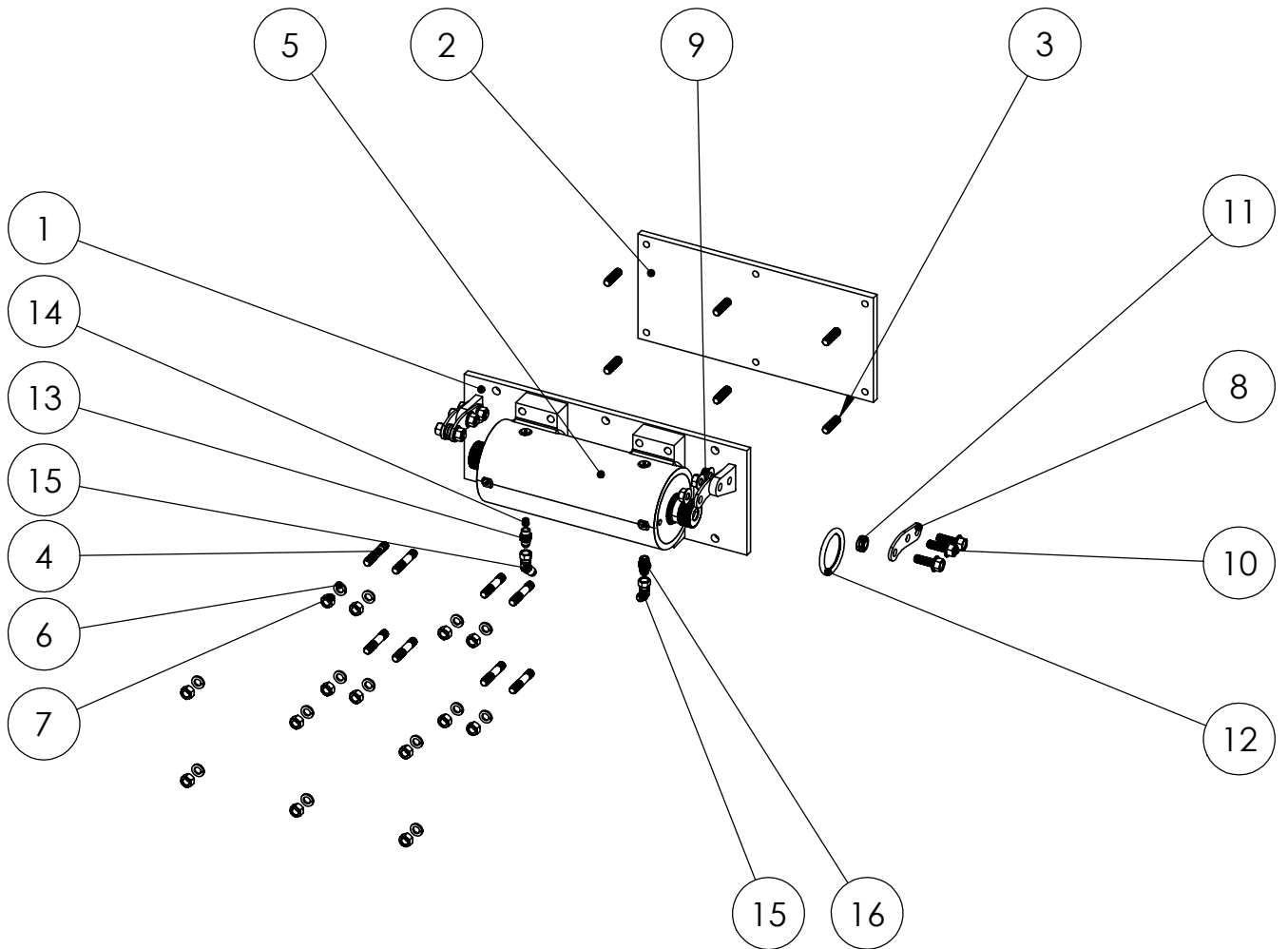

DO NOT SCALE DRAWING		MAINFRAME SUB ASSY PARTS	
UNLESS OTHERWISE SPECIFIED: DIMENSIONS ARE IN INCHES TOLERANCES: FRACTIONAL: ±1/32 ANGULAR: MACH ±1° BEND ±1° TWO PLACE DECIMAL ±0.010 THREE PLACE DECIMAL ±0.005		BU19*** BW18400 ACT	
DRAWN BY: R WYMAN		DRAWING NO BWA19014 PARTS	REV 00
DATE: 7/25/2023		SCALE: 1:12	WEIGHT: 129.079 # SHEET 1 OF 1
MATERIAL: NOTED			



BARKER PRODUCTS
1310 MILLER ROAD
GREENVILLE, SC
29607

ITEM NO.	PART NUMBER	DESCRIPTION	QTY.
1	BW19290	LIFT PLATE	1
2	BW00800	SADDLE	1
3	XEA061000	3/8 LOCKWASHER	9
4	XDA061600	3/8-16 HEX NUT	9
5	BW10675	CAN SUPPORT	2
6	XAD061616	3/8-16 X 2 FSHCS	6
7	BW19110	SLIDE SPACER	2
8	BW19100	SLIDE CAP	2
9	XAA061610	3/8-16 X 1 1/4 HHCS	3

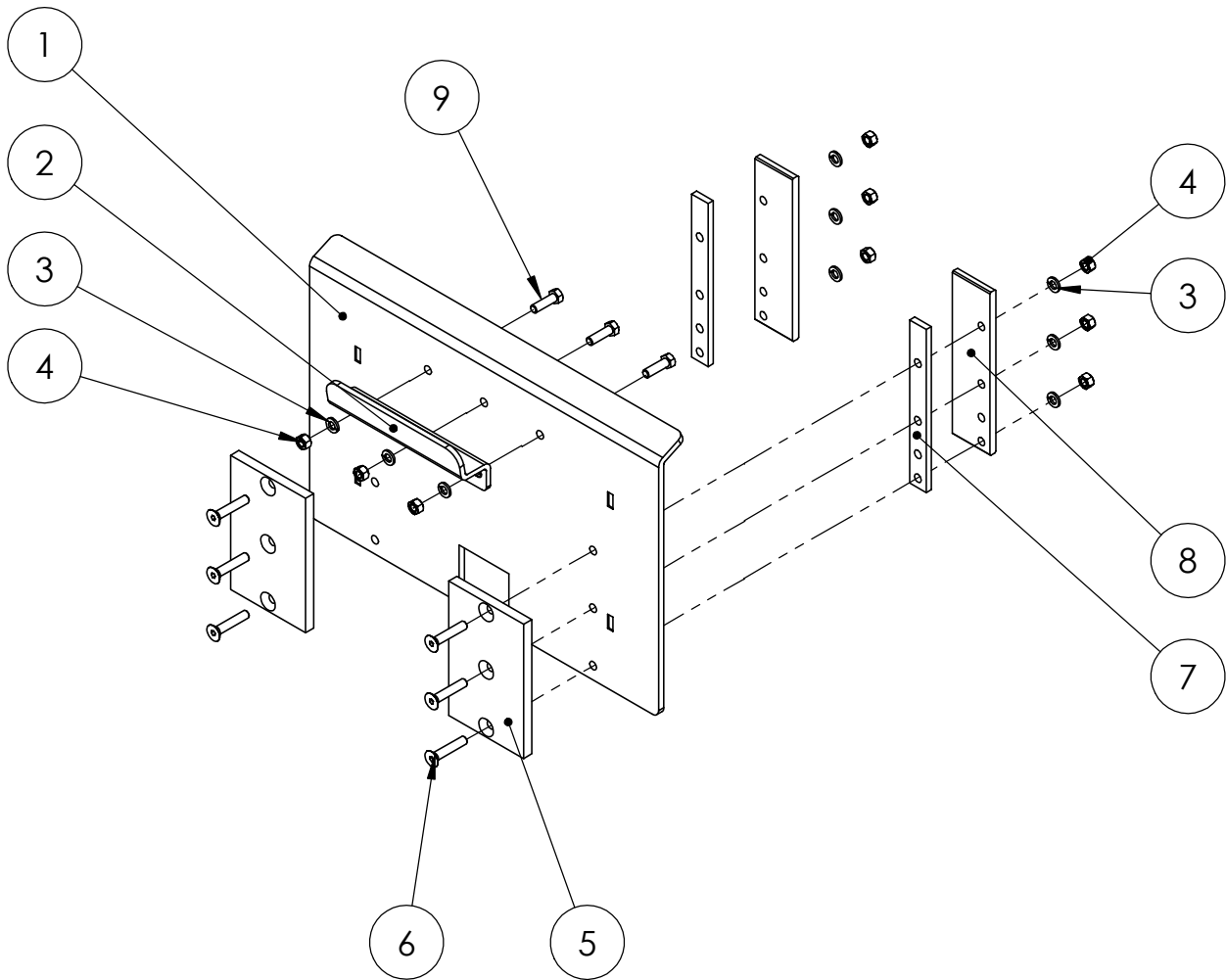

BARKER PRODUCTS
1310 MILLER ROAD
GREENVILLE, SC
29607

DRAWN BY: R WYMAN
DATE: 2/24/2022
MATERIAL: NOTED

DO NOT SCALE
DRAWING
UNLESS OTHERWISE SPECIFIED:
DIMENSIONS ARE IN INCHES
TOLERANCES:
FRACTIONAL ±1/32
ANGULAR: MACH ±1° BEND ±1°
TWO PLACE DECIMAL ±0.010
THREE PLACE DECIMAL ±0.005

LIFT PLATE SUB ASSY

DRAWING NO
BWA19290

REV
00

SCALE: 1:8

WEIGHT: 38.632 #

SHEET 1 OF 1

ITEM NO.	PART NUMBER	DESCRIPTION	QTY.
1	BW10230	SLIDE PLATE	1
2	XAD061606	3/8-16 X 3/4 FHSCS	12
3	BW10240	SLIDE SUPPORT	4
4	BW10100	HOOK SHAFT	1
5	BW10110	SPRING SHAFT	1
6	BW02125	5/32 X 3/4 SPRING PIN	2
7	BW10120	HOOK SPRING	2
8	BW19285	SLIDE DRIVE	2
9	BW10680	LOWER HOOK	1
10	BW19286	SLIDE DRIVE EXTENSION	4
11	BW19287	EXTENSION SPACER	2
12	XAE061612	3/8-16 X 1 1/2 FLANGED HHCS	6
13	XAE081312	1/2-13 X 1 1/2 FLANGED HHCS	6
15	BW99108	1/2" SPHERICAL BEARING	2
16	XDH081300	1/2-13 FLANGED NUT	2

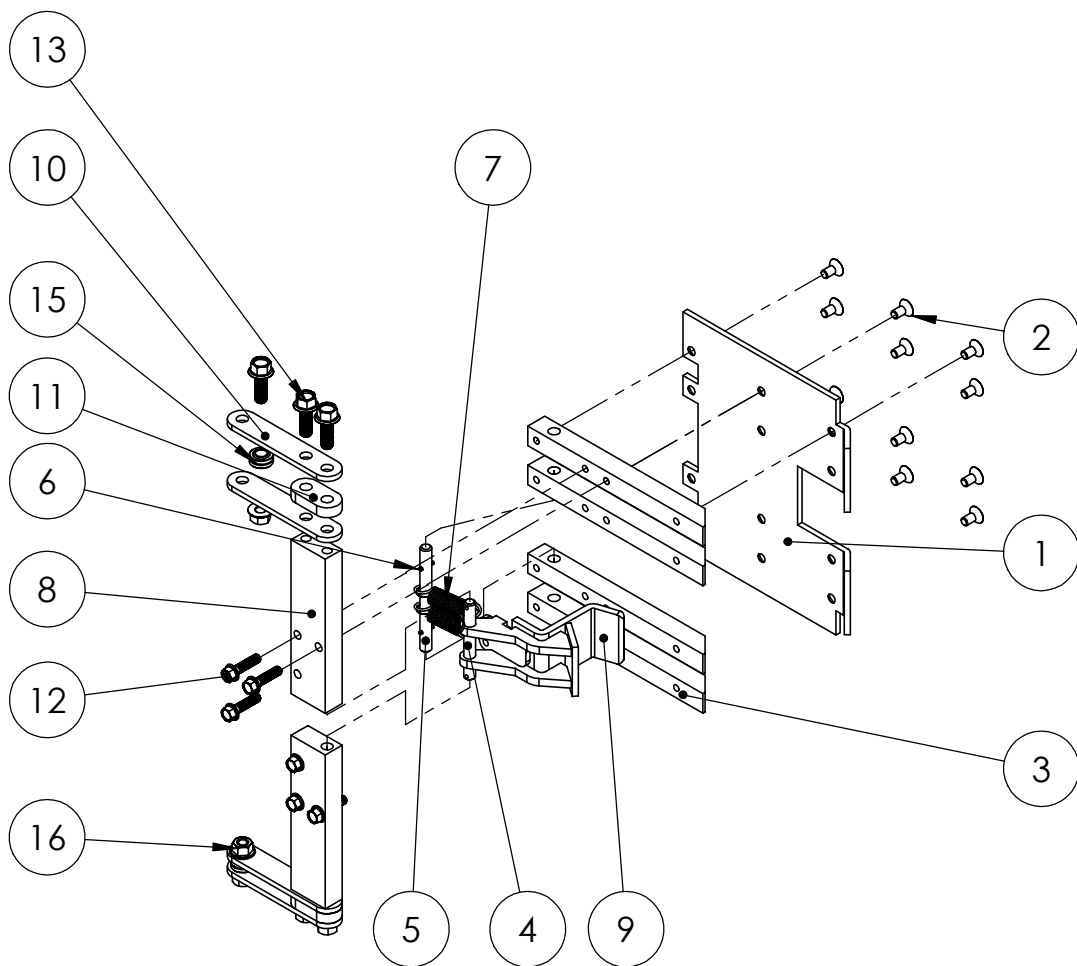

DO NOT SCALE DRAWING		SLIDE SUB ASSY BU19XXX	
UNLESS OTHERWISE SPECIFIED: DIMENSIONS ARE IN INCHES TOLERANCES: FRACTIONAL: ±1/32 ANGULAR: MACH ±1° BEND ±1° TWO PLACE DECIMAL ±0.010 THREE PLACE DECIMAL ±0.005		DRAWING NO BWA19280	REV 00
MATERIAL: NOTED		SCALE: 1:8	WEIGHT: 33.294 # SHEET 1 OF 1



BARKER PRODUCTS
1310 MILLER ROAD
GREENVILLE, SC
29607

DRAWN BY: R WYMAN
DATE: 7/25/2023
MATERIAL: NOTED