



BP Lifts
By Barker Products
1310 Miller Road, Greenville, SC 29607



Model BPH27-5541 Lift

Part # BU19741



- Dependable Smooth Acting 27K Helical Rotary Actuator
- Splined Shafts To Eliminate Arm Movement And Wear
- 50 Degree Dump Angle
- No Grease Points
- EZ Bolt On Kit Standard
- Meets ANSI Z245 Type B Specs
- Lifts All Standard American 2 Bar Carts
- Lift Plate Arc Motion Makes Cart Attachment Fast And Easy On Unlevel Highway Conditions
- Double Wide Mounting Plate Available. Increases Hopper Height To Decrease Packing Cycles
- 39 to 44 Inch Mounting Height
- 15 3/16 to 20 3/16 Inch Ground Clearance
- Use on Rear Loaders without kick bars

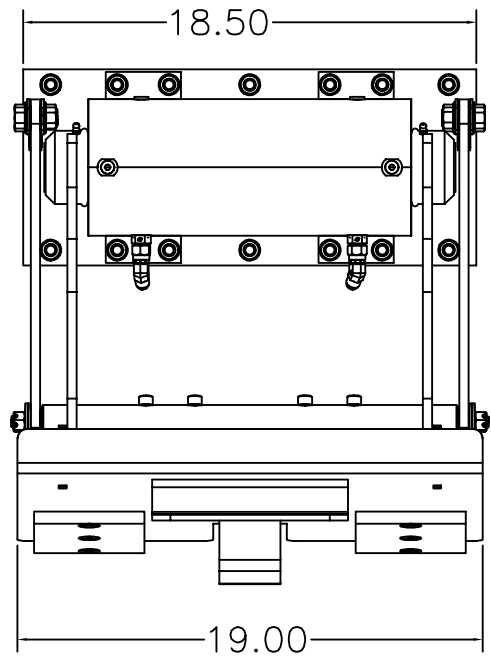
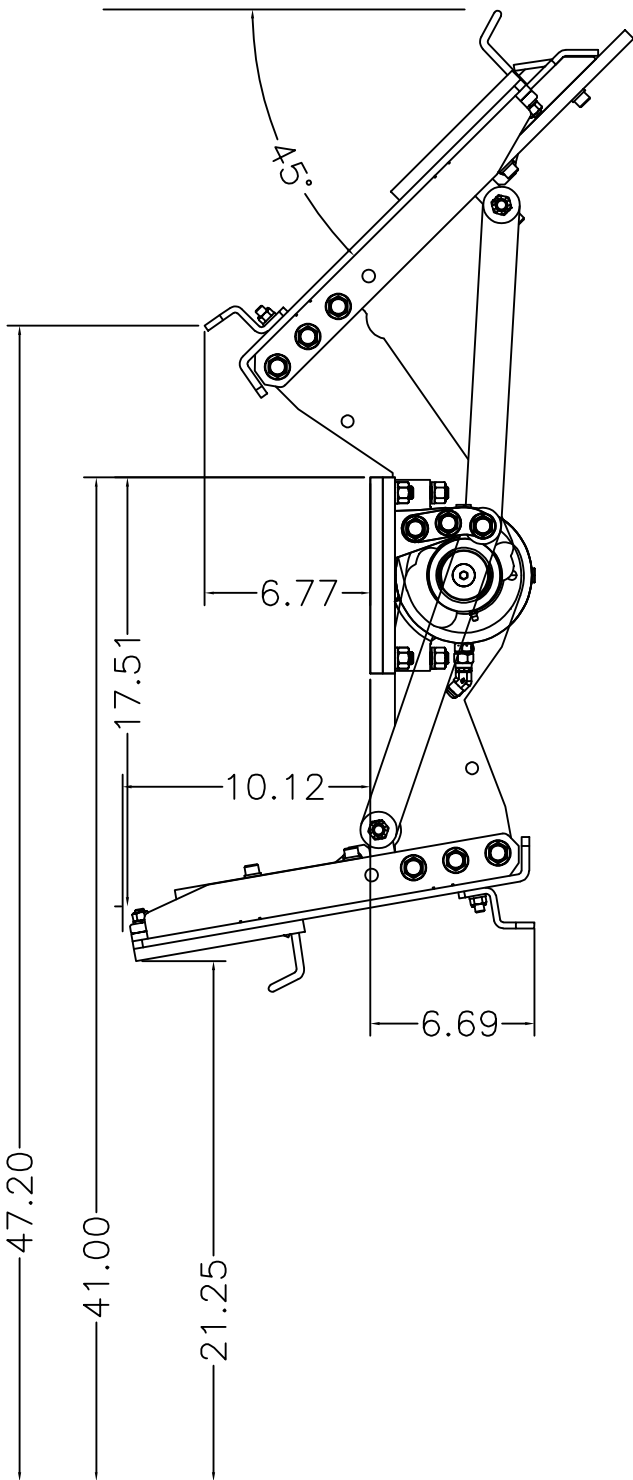
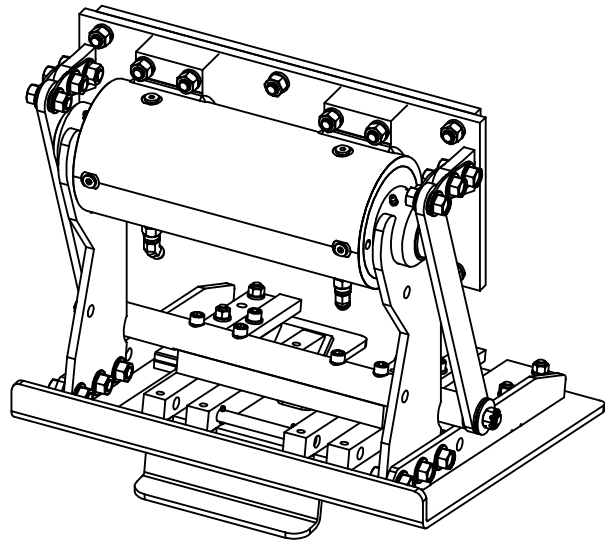

BARKER PRODUCTS
1310 MILLER ROAD
GREENVILLE, SC
29607

DRAWN BY: R WYMAN

DATE: 9/22/2022

MATERIAL: NOTED

DO NOT SCALE
DRAWING
UNLESS OTHERWISE SPECIFIED
DIMENSIONS ARE IN INCHES
TOLERANCES:
FRACTIONAL $\pm 1/32$
ANGULAR: MACH $\pm 1^\circ$ BEND $\pm 1^\circ$
TWO PLACE DECIMAL ± 0.010
THREE PLACE DECIMAL ± 0.005

HB27-8041 LIFT
BW18400 ACTUATOR

DRAWING NO
BU18741

REV
00

SCALE: 1:8

WEIGHT: 215.152 #

SHEET 1 OF 1

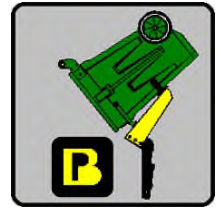
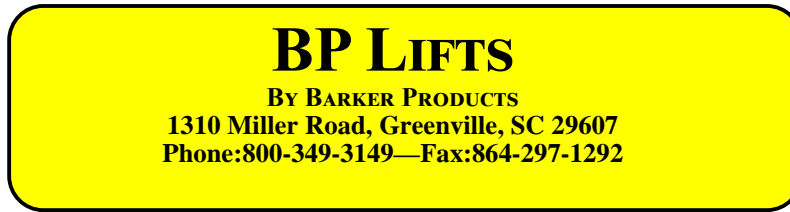

BPHB27-19XXX SERIES LIFT UNIT WARRANTY

Barker Products warrants each new dump unit to be free of defects in material and workmanship under normal use and service for a period of 1 year or 2000 hours of operation, whichever comes first, from the date of delivery.

This warranty excludes any obligations by BARKER PRODUCTS for the cost of down time. BARKER PRODUCTS will not warranty any dump unit which has been subject to misuse, neglect, alteration, or damaged by an accident.

On any work not performed by BARKER PRODUCTS or it's representative, the customer will be responsible for freight charges on all parts shipped under warranty. Parts will be invoiced at time of shipment. Defective parts must be returned to BARKER PRODUCTS within 30 days. If the part is determined to be defective the customer will be credited for the original invoice.

Customer warranty labor charges must be approved by BARKER PRODUCTS in advance. If not contacted for approval, BARKER PRODUCTS will not be liable for the warranty labor charge.

Limit hydraulic input pressure to 1700 PSI

ITEM NO.	PART NUMBER	DESCRIPTION	QTY.
1	BWA19600	MAINFRAME SUB ASSY	1
2	BW18005	SPLINE CAP HB25	2
3	XAD081312	1/2-13 X 1 1/2 FHSCS	2
4	BW18130	LEFT LIFT ARM	1
5	BWA19520	LP SUB ASSY	1
6	XAE081310	1/2-13 X 1 1/4 FLANGED HHCS	6
7	XDH081300	1/2-13 FLANGED NUT	6
8	BWA19540	HOOK SUB ASSY	1
9	BW19555	HOOK LINK	2
10	BW99108	1/2" SPHERICAL BEARING	2
11	BW18140	RIGHT LIFT ARM	1
12	XAA081314	1/2-13 1 3/4 HHCS	2
13	XEA082412SS	FLAT WASHER 1/2X11/2X1/8	2
14	XDA081300	1/2-13 HEX NUT	2

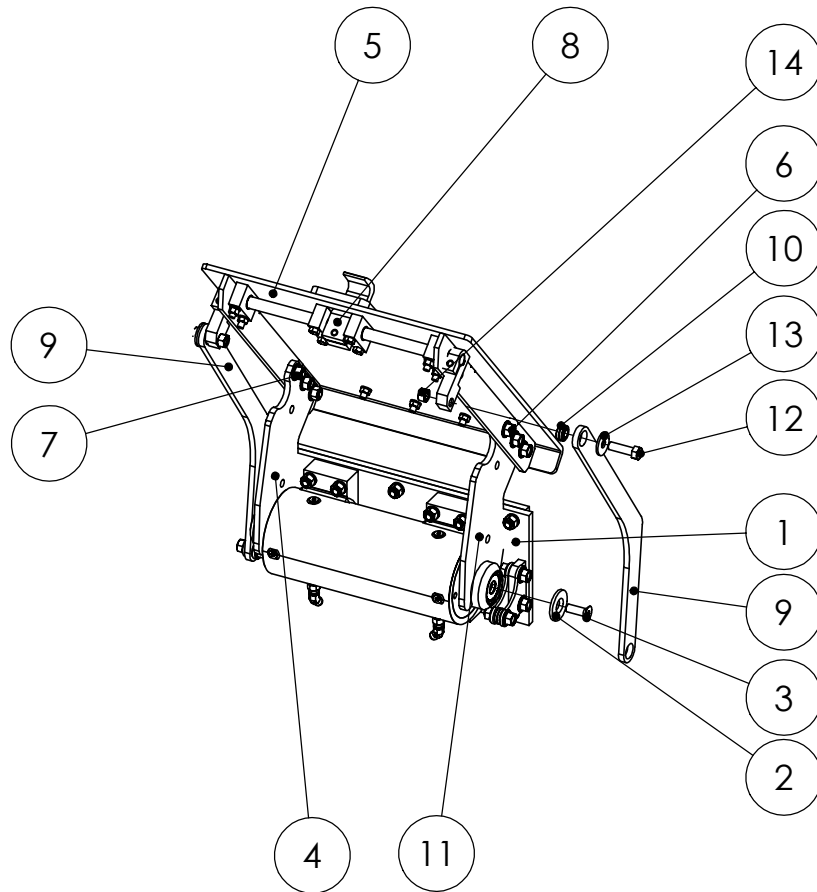

BARKER PRODUCTS
1310 MILLER ROAD
GREENVILLE, SC
29607

DRAWN BY: R WYMAN
DATE: 6/22/2022
MATERIAL: NOTED

DO NOT SCALE
DRAWING
UNLESS OTHERWISE SPECIFIED:
DIMENSIONS ARE IN INCHES
TOLERANCES:
FRACTIONAL ±1/32
ANGULAR: MACH ±1° BEND ±1°
TWO PLACE DECIMAL ±0.010
THREE PLACE DECIMAL ±0.005

BPHR27-5541 PARTS
BW18400 ACTUATOR

DRAWING NO.
BU19741 PARTS

REV
00

SCALE: 1:12 WEIGHT: 197.697 # SHEET 1 OF 1

ITEM NO.	PART NUMBER	DESCRIPTION	QTY.
1	BW17130	HOOK BEARING MOUNT	4
2	BW03195	12-DU-12 BEARING	4
3	BW00800	SADDLE	1
4	BW19520	LIFT PLATE	1
5	BW19570	CAN SUPPORT	1
6	XAA061610	3/8-16 X 1 1/4 HHCS	3
7	XAH061620	3/8-16 X 2 1/2 CARRIAGE BOLT	4
8	XEB061000	3/8 LOCK WASHER	7
9	XDA061600	3/8-16 HEX NUT	7
10	XAA061616	3/8-16 X 2 1/4 HHCS	4

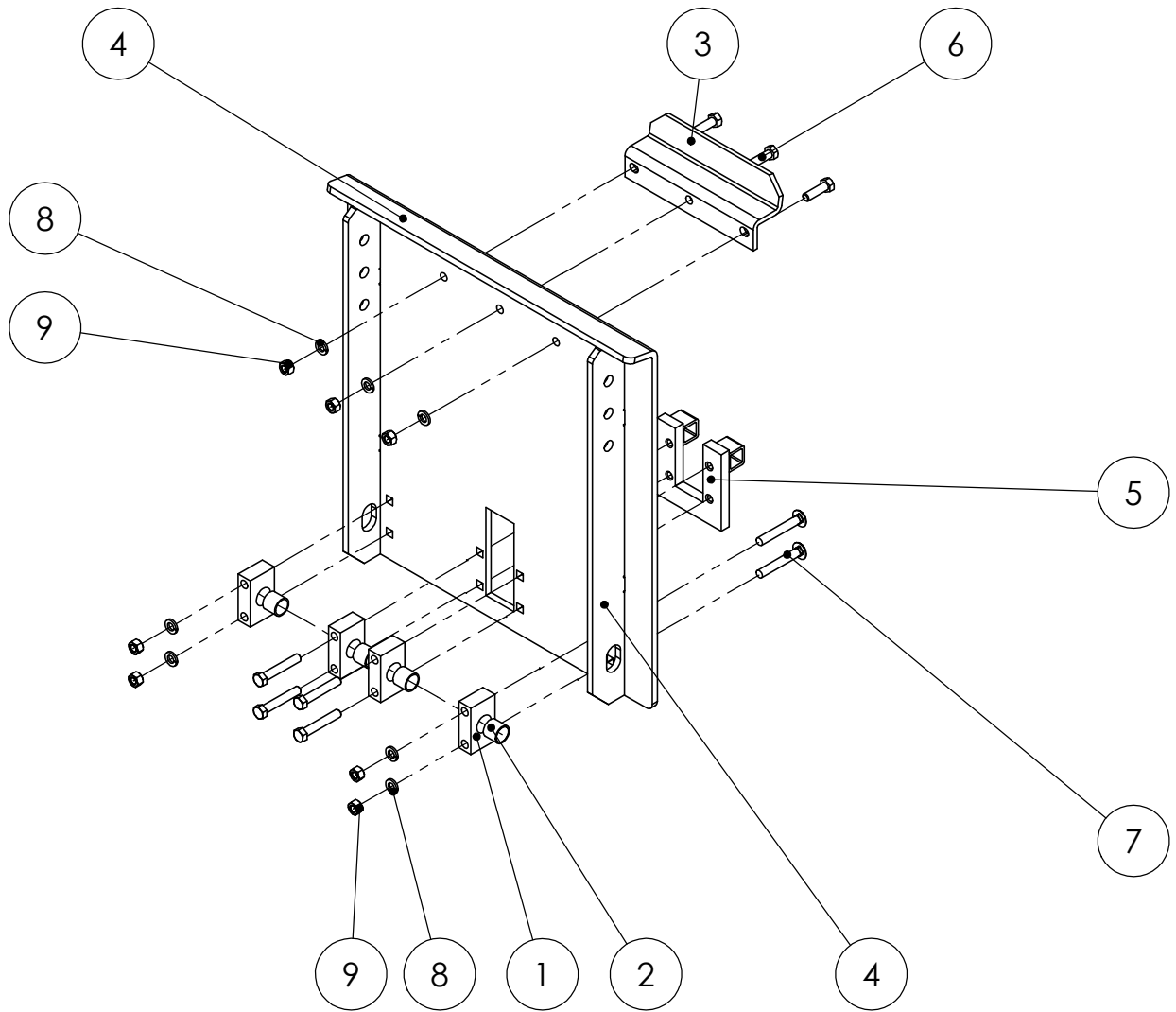

DO NOT SCALE DRAWING		LIFT PLATE SUB ASSY	
UNLESS OTHERWISE SPECIFIED: DIMENSIONS ARE IN INCHES TOLERANCES: FRACTIONAL ±1/32 ANGULAR: MACH ±1° BEND ±1° TWO PLACE DECIMAL ±0.010 THREE PLACE DECIMAL ±0.005		DRAWING NO BWA19520	REV 00
SCALE: 1:8	WEIGHT: 46.783 #	SHEET 1 OF 1	



BARKER PRODUCTS
1310 MILLER ROAD
GREENVILLE, SC
29607

DRAWN BY: R WYMAN
DATE: 7/16/2020
MATERIAL: NOTED

ITEM NO.	PART NUMBER	DESCRIPTION	QTY.
1	BW19600	MAINFRAME	1
2	BW17525	MOUNT PLATE - N	1
3	BW07140	PLATE STUD	6
4	BW07105	ACTUATOR MOUNT STUD	8
5	BW18400	ACTUATOR	1
6	XEB081000	1/2 LOCKWASHER	14
7	XDA082000	1/2-20 HEX NUT	14
8	BW18002	O-RING GREASE SEAL	2
9	BV00025	116 X 1/8 NPT ORIFICE PLUG	1
10	BV00064	6T X 6S ORIFICE FITTING	1
11	BR04842	6502-06-06 MJ-FJS 45 DEG	2
12	BR03830	6400-06-06 M TUBE TO O-RING	1
13	BW19565	HOOK LINK PIVOT CAP	4
14	BW99108	1/2" SPHERICAL BEARING	2
15	XDH081300	1/2-13 FLANGED NUT	6
16	XAE081312	1/2-13 X 1 1/2 FLANGED HHCS	6

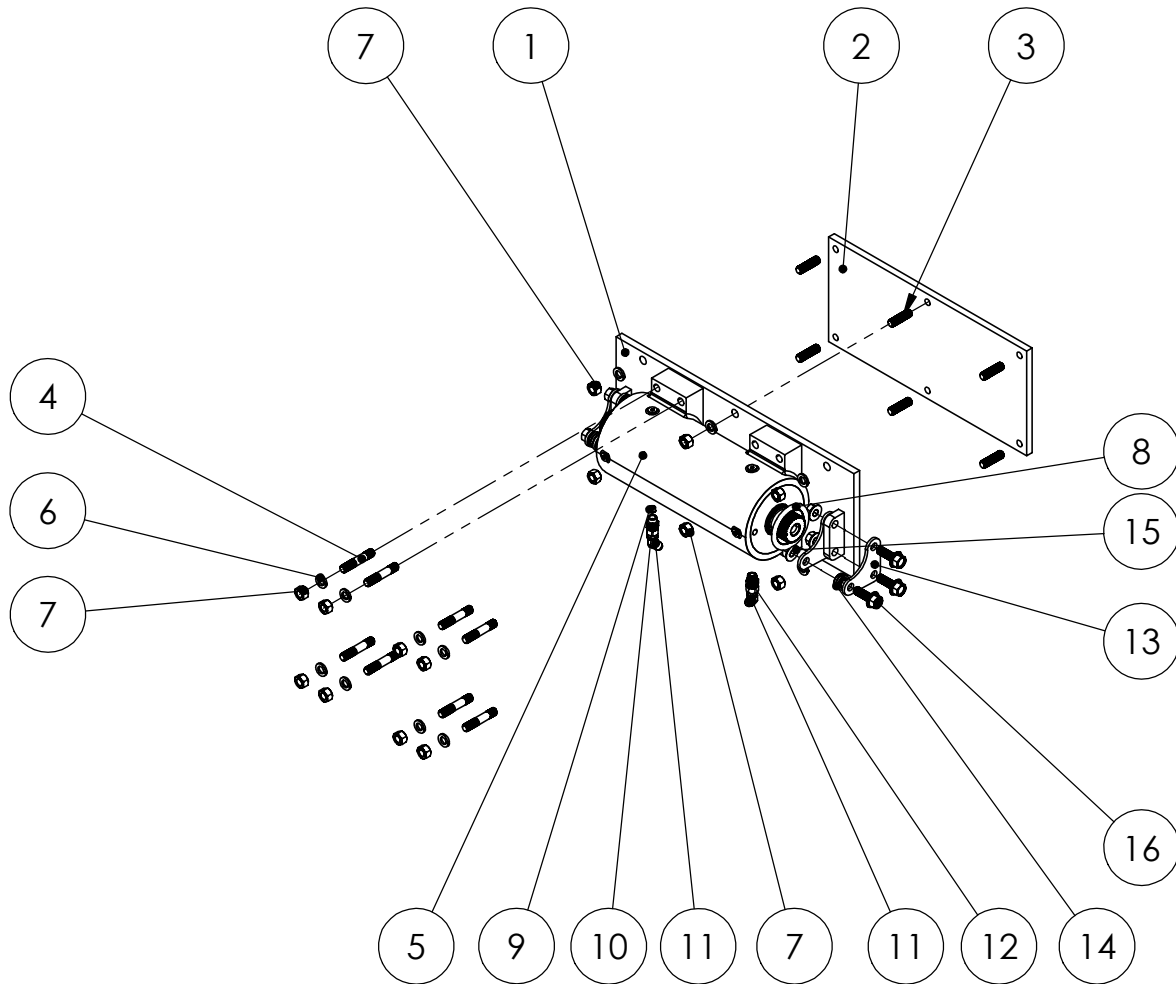

DO NOT SCALE DRAWING		MAINFRAME SUB ASSY PARTS BU19741 BW18400 ACTUATOR	
UNLESS OTHERWISE SPECIFIED: DIMENSIONS ARE IN INCHES TOLERANCES: FRACTIONAL ±1/32 ANGULAR: MACH ±1° BEND ±1° TWO PLACE DECIMAL ±0.010 THREE PLACE DECIMAL ±0.005		DRAWING NO BWA19600 PARTS	REV 00
SCALE: 1:12		WEIGHT: 126.392 #	SHEET 1 OF 1



BARKER PRODUCTS
1310 MILLER ROAD
GREENVILLE, SC
29607

DRAWN BY: R WYMAN
DATE: 6/21/2022
MATERIAL: NOTED

ITEM NO.	PART NUMBER	DESCRIPTION	QTY.
1	BW19540	HOOK SHAFT	1
2	BW07560	WOODRUFF KEY #806	3
3	BW06780	HOOK DRIVE	2
4	BW07490	HOOK	1
5	XAB061612	3/8-16 X 1 1/2 HHCS	3

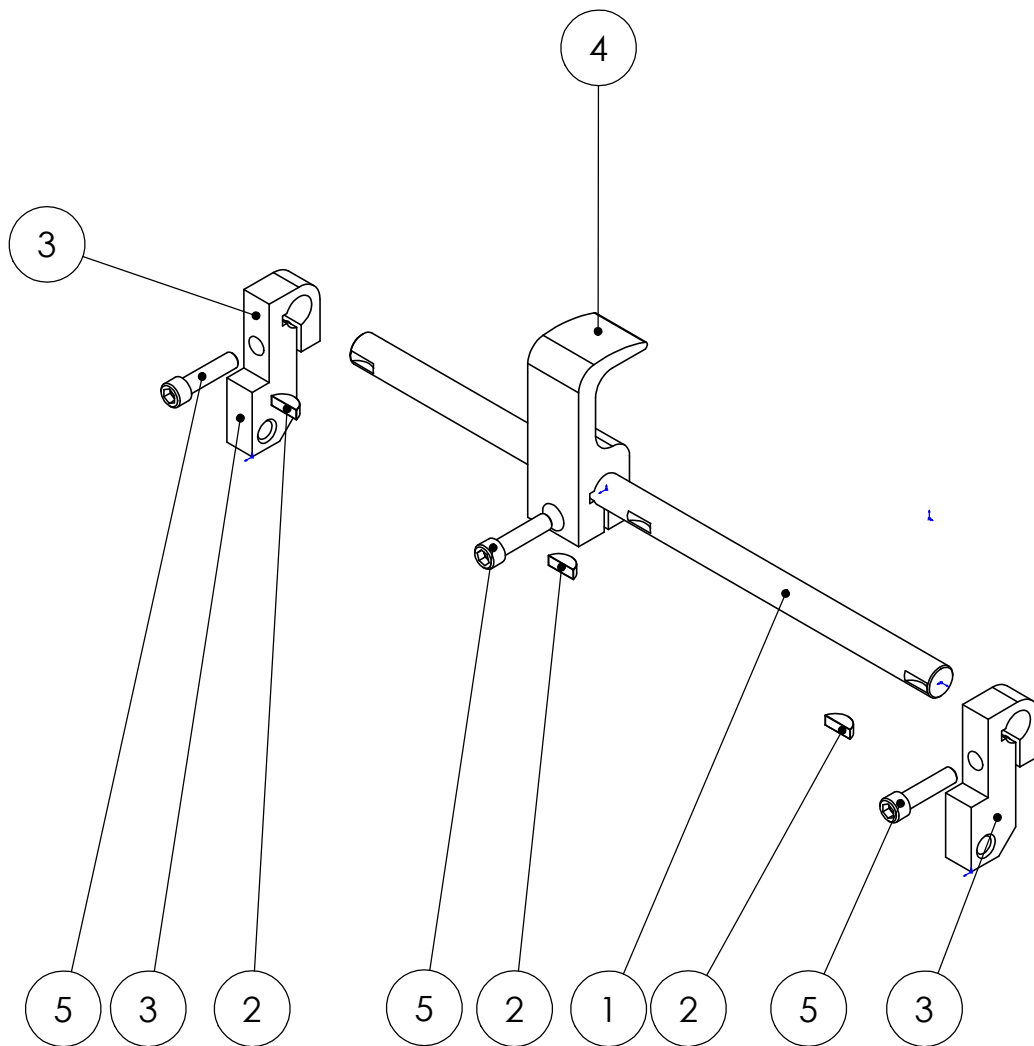

DO NOT SCALE DRAWING		HOOK SUB ASSY	
UNLESS OTHERWISE SPECIFIED: DIMENSIONS ARE IN INCHES TOLERANCES: FRACTIONAL ±1/32 ANGULAR: MACH ±1° BEND ±1° TWO PLACE DECIMAL ±0.010 THREE PLACE DECIMAL ±0.005		DRAWING NO BWA19540	REV 00
SCALE: 1:4	WEIGHT: 5.450 #	SHEET 1 OF 1	



BARKER PRODUCTS
1310 MILLER ROAD
GREENVILLE, SC
29607

DRAWN BY: R WYMAN
DATE: 7/16/2020
MATERIAL: NOTED