



## *BP LIFTS*

BY BARKER PRODUCTS  
1310 Miller Road, Greenville, SC 29607  
Phone:800-349-3149—Fax:864-297-1292



# *Model BPH2-15 Series Lifts*



- **Meets ANSI Z245 Type B Specifications**
- **Powered By The Dependable Smooth Acting Helical Rotary Actuator**
- **Splined Shafts To Eliminate Arm Movement And Wear**
- **EZ Bolt On Kit Standard**
- **Heavy Duty Cast Iron Bushings For Long Lift Cycle**
- **37" To 45" Mounting Heights Available**
- **16" Ground Clearance**



**BP LIFTS**  
By Barker Products  
1310 Miller Road, Greenville, SC 29607 Phone:800-349-3149

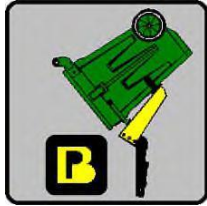

# BPH2-1537 Envelope Dimensions

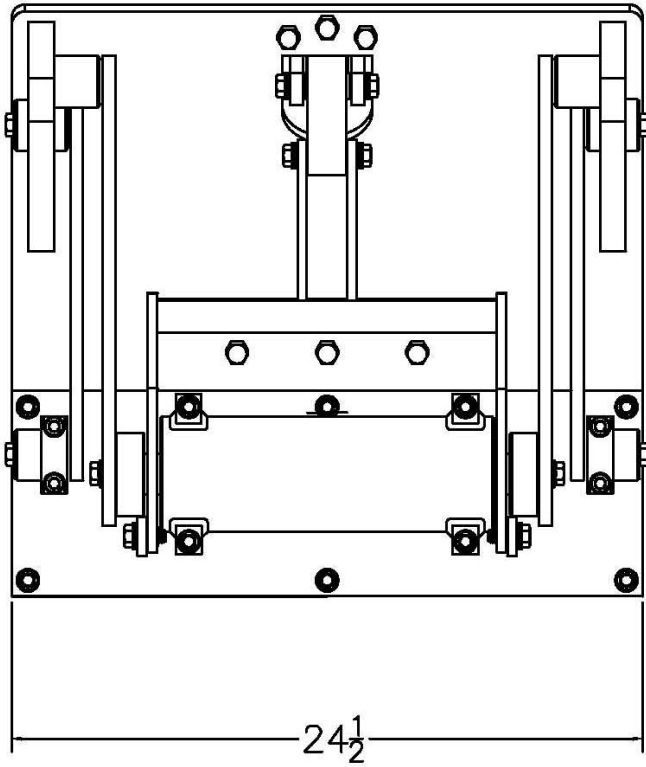
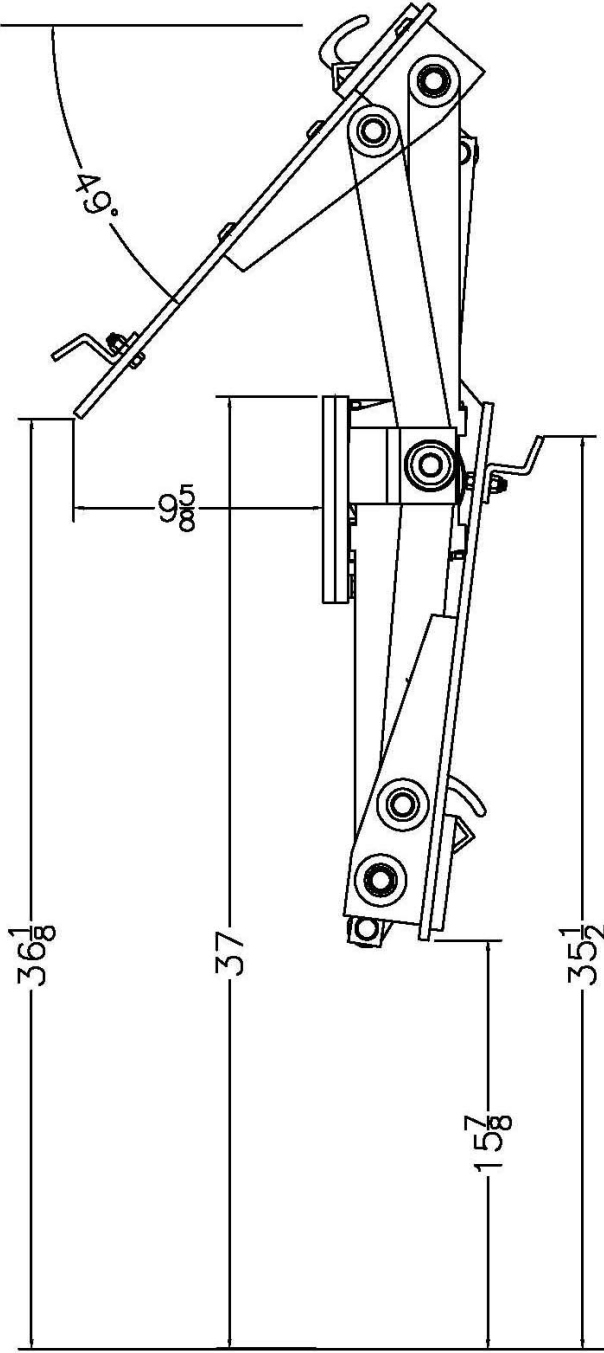

GROUND LEVEL

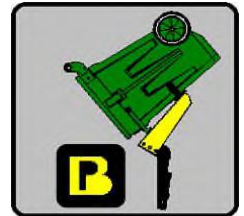
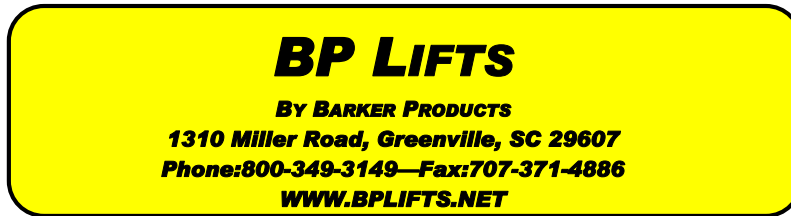

# Lift Unit Installation

1. Truck must be empty, clean and parked on a level surface before installation is started.
2. Remove all bumpers and running boards that will interfere with the location of the lift units. Relocate lower mounted tail lights as needed.
3. Measure and mark the centerline of the truck hopper. The centerline of the unit or units should be a minimum of 17" from the hopper centerline.
4. Hand valves should be mounted on the side of the hopper at the most convenient height for the operator and clear of the packer controls.
5. The top of the unit mounting plate should be tack welded in place at the height recommended on the envelope dimension sheet of the unit.  
**CAUTION: SEE NOTE BELOW PICTURE**
6. All dimensions should be approved by the customer before final welding.
7. If the mounting plate extends more than 2" above the hopper, a brace should be added.

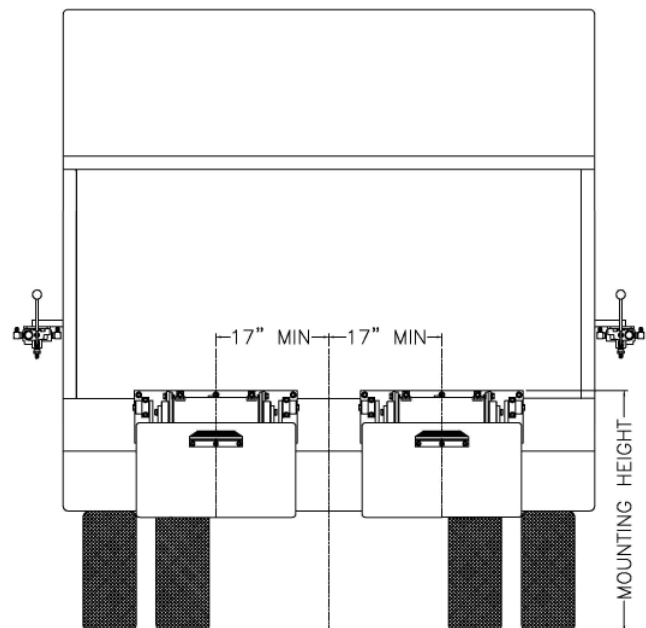

Mounting heights and locations are recommendations only. It is the responsibility of the installer to insure that the customer is satisfied with the height. Barker Products recommends that after the units are tacked in place, try the units with the can or cans the customer uses. The customer should approve your mount before final welding.

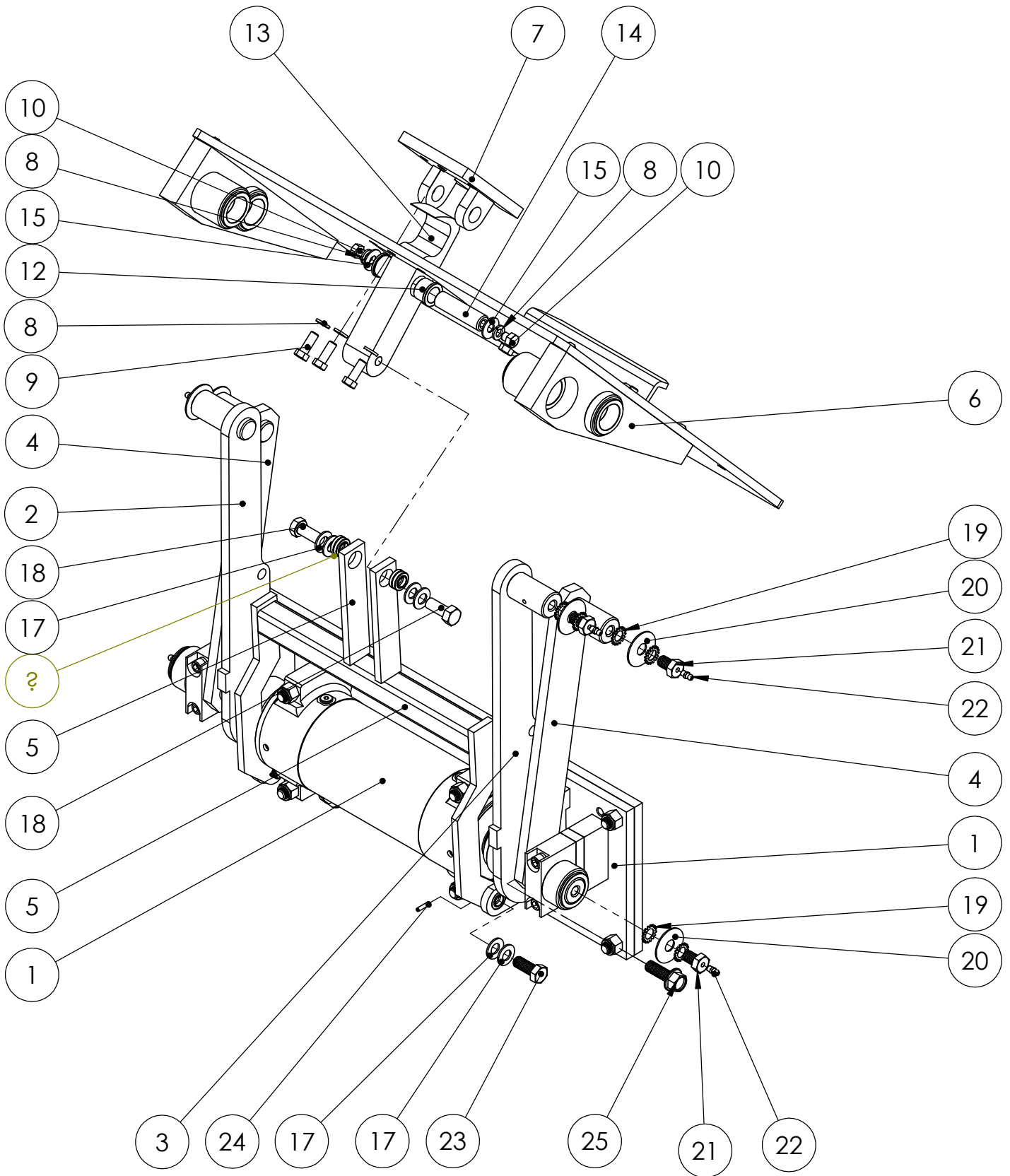

DO NOT SCALE DRAWING		BPH2-1537 LIFT PARTS	
UNLESS OTHERWISE SPECIFIED: DIMENSIONS ARE IN INCHES TOLERANCES: FRACTIONAL $\pm 1/32$ ANGULAR: MACH $\pm 1^\circ$ BEND $\pm 1^\circ$ TWO PLACE DECIMAL $\pm 0.010$ THREE PLACE DECIMAL $\pm 0.005$		DRAWING NO BU09737 PARTS	REV 00
MATERIAL: NOTED		SCALE: 1:6	WEIGHT: 224.797 # SHEET 1 OF 2



**BARKER PRODUCTS**  
1310 MILLER ROAD  
GREENVILLE, SC  
29607

DRAWN BY: R WYMAN  
DATE: 1/11/2019  
MATERIAL: NOTED

ITEM NO.	PART NUMBER	DESCRIPTION	EXPLODED PARTS/QTY.
1	BWA09070	MAINFRAME SUB ASSY	1
2	BW11300	LEFT LIFT ARM	1
3	BW11305	RIGHT LIFT ARM	1
4	BW09737	GUIDE ARM	2
5	BW09500	HOOK LINK	1
6	BWA09020	LIFT PLATE SUB ASSY	1
7	BW00815	HOOK MOUNT	1
8	XEB061000	3/8" LOCK WASHER	5
9	XAA061608	3/8-16 X 1 HHCS	3
10	XAA061606	3/8-16 X 3/4 HHCS	2
18	XAA081310	1/2-13 X 1 1/4 HHCS	1
12	BW00940	HOOK BEARING	2
13	BW09040	HOOK	1
14	BW00830	HOOK SHAFT	1
15	XEA061000	3/8 FLAT WASHER	2
16	BW99308	1/2" SPHERICAL BEARING	2
17	BW02100	1/2" BELLEVILLE SPRING WASHER	8
18	XAA081310	1/2-13 X 1 1/4 HHCS	1
19	BW02150	1/2" EXTERNAL TOOTH LOCK WASHER	12
20	BW07115	BEARING CAP WASHER	6
21	BW07110	BEARING CAP BOLT	6
22	BW01110	GREASE FITTING - 1/4-28 SHORT	6
23	BW02140	1/2-13 X 1 1/4 LOCK BOLT	2
24	BW02125	5/32 X 3/4 SPRING PIN	2
25	XAE081312	1/2-13 X 1 1/2 FLANGED HHCS	2



**BARKER PRODUCTS**  
1310 MILLER ROAD  
GREENVILLE, SC  
29607

DRAWN BY: R WYMAN  
DATE: 1/11/2019  
MATERIAL: NOTED

DO NOT SCALE  
DRAWING  
UNLESS OTHERWISE SPECIFIED:  
DIMENSIONS ARE IN INCHES  
TOLERANCES:  
FRACTIONAL ±1/32  
ANGULAR: MACH ±1° BEND ±1°  
TWO PLACE DECIMAL ±0.010  
THREE PLACE DECIMAL ±0.005

BPH2-1537 LIFT PARTS

DRAWING NO  
BU09737 PARTS

REV  
00

SCALE: 1:1 WEIGHT: 224.797 # SHEET 2 OF 2

ITEM NO.	PART NUMBER	DESCRIPTION	MAINFRAME PARTS EXPLODED/QTY.
1	BW09070	MAINFRAME - H2-15	1
2	BZ09014	GUIDE ARM SPACER	2
3	BW99308	1/2" SPHERICAL BEARING	2
4	BW07030	MOUNT PLATE H	1
5	BW07140	PLATE STUD	6
6	XDC082000	1/2-20 NYLOK NUT	10
7	BW07125	ACTUATOR MOUNT STUD	4
8	BW07000	15K ACTUATOR	1
9	BW10080	TOP BEARING	2
10	BW00934	CAST FLANGE BUSHING	4
11	XEC0806080	1/2" HC LOCK WASHER	4
12	XAB082024	1/2-20 X 3 SHCS	4
13	BV00055	093 X 6T4S45 ORIFICE FITTING	1
14	BR05285	6802-06-04-NWO	1
15	BW07001	O-RING GREASE SEAL	2

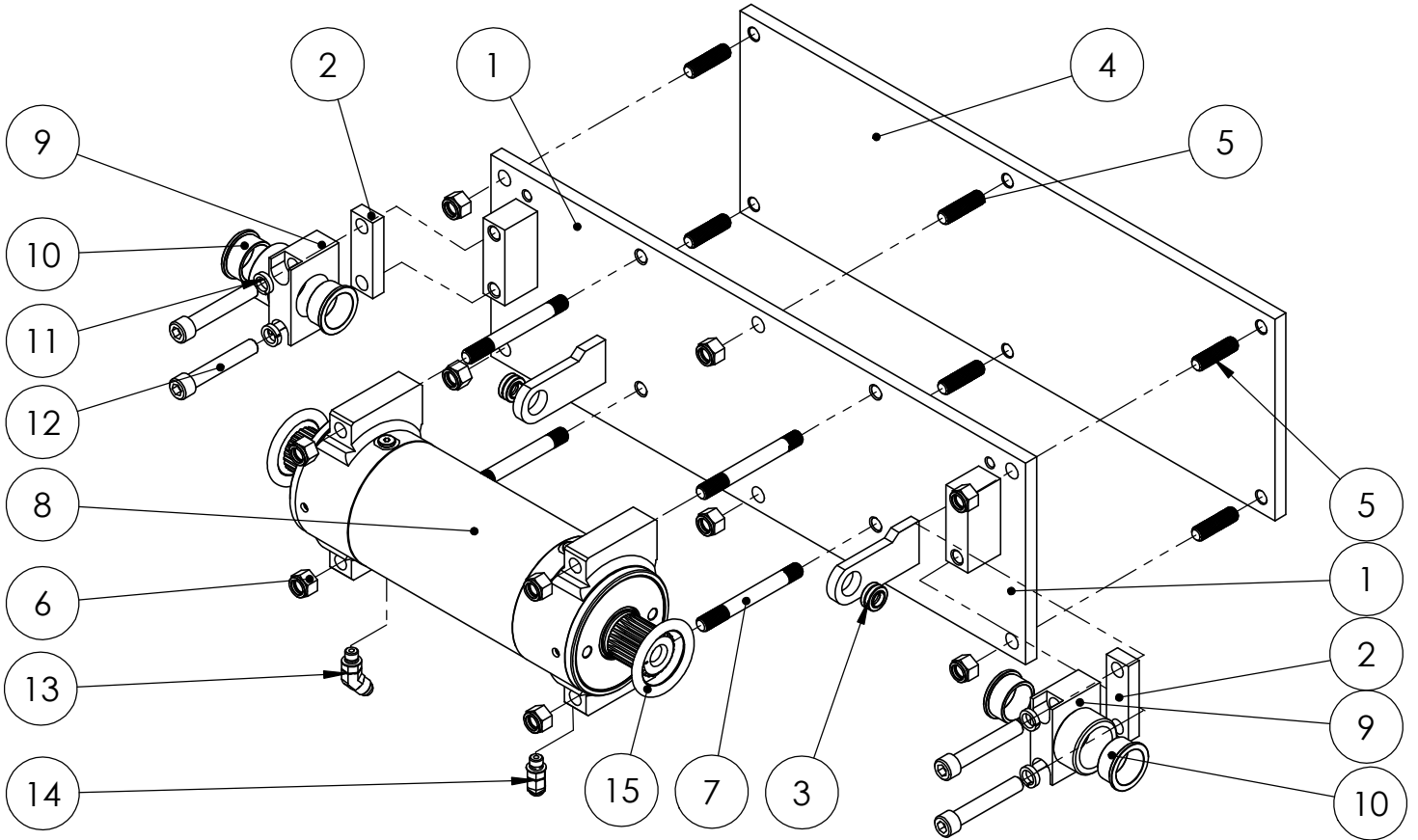

DO NOT SCALE DRAWING		MAINFRAME SUB ASSY H2-15 UNITS	
UNLESS OTHERWISE SPECIFIED: DIMENSIONS ARE IN INCHES TOLERANCES: FRACTIONAL ±1/32 ANGULAR: MACH ±1° BEND ±1° TWO PLACE DECIMAL ±0.010 THREE PLACE DECIMAL ±0.005		DRAWING NO BWA09070	REV 00
SCALE: 1:6		WEIGHT: 113.296 # SHEET 1 OF 1	



**BARKER PRODUCTS**  
1310 MILLER ROAD  
GREENVILLE, SC  
29607

DRAWN BY: R WYMAN  
DATE: 8/10/2017  
MATERIAL: NOTED

ITEM NO.	PART NUMBER	DESCRIPTION	EXPLODED PARTS VIEW/QTY.
1	BW09020	LIFT PLATE - H	1
2	BW00800	SADDLE	1
3	XAA061610	3/8-16 X 1 1/4 HHCS	3
4	XDC061600	3/8-16 NYLOK NUT	3
5	BW10040	RIGHT LP MOUNT	1
6	BW10030	LEFT LP MOUNT	1
7	XAC081308	1/2-13 X 1 BHCS	6
8	BW00934	CAST FLANGE BUSHING	8

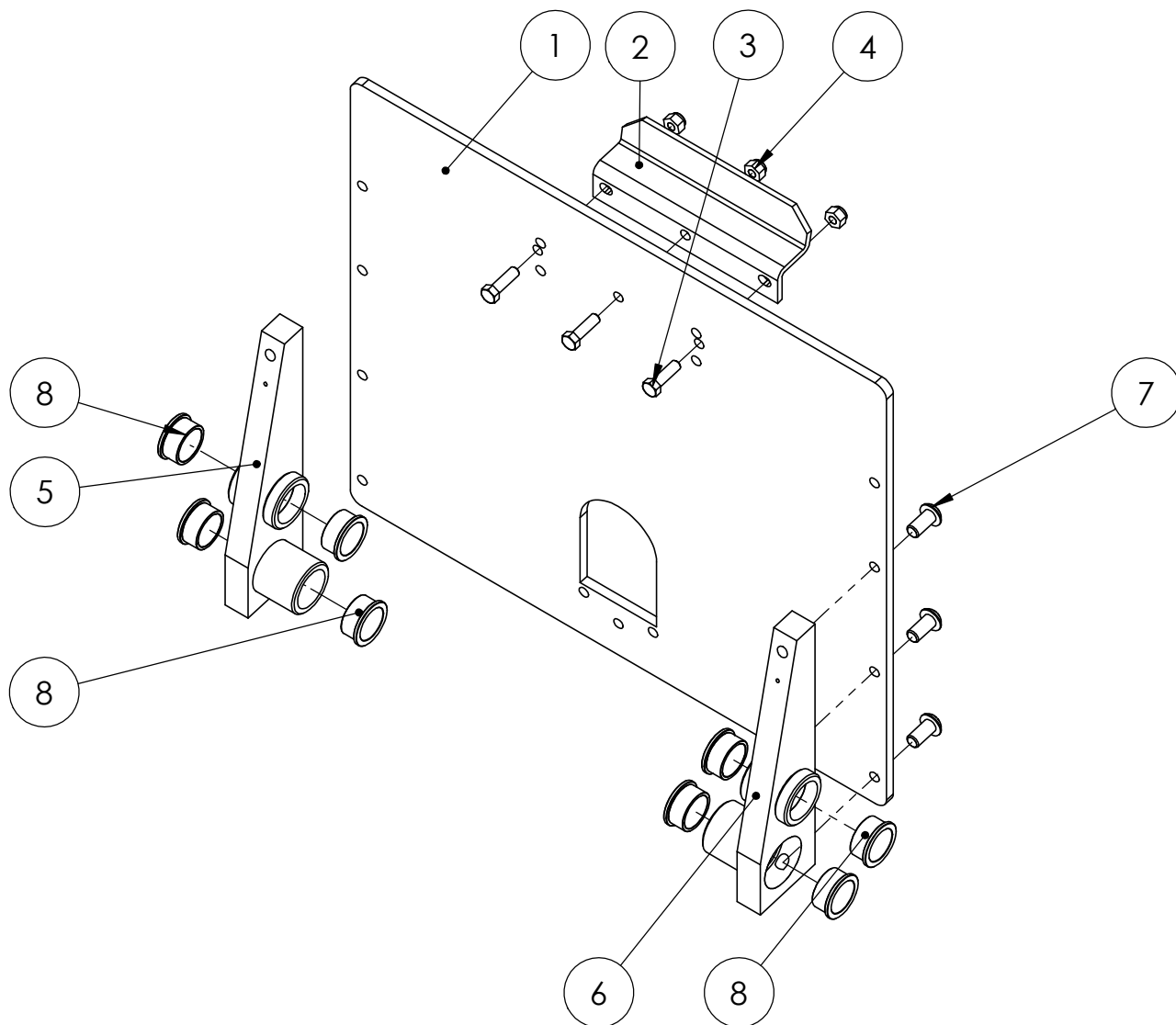

DO NOT SCALE DRAWING		LIFT PLATE SUB ASSY	
UNLESS OTHERWISE SPECIFIED: DIMENSIONS ARE IN INCHES		DRAWING NO	
TOLERANCES:		BWA09020 PARTS	
FRACTIONAL ±1/32		SCALE: 1:6	REV 00
ANGULAR: MACH ±1° BEND ±1°		WEIGHT: 67.134 #	SHEET 1 OF 1
TWO PLACE DECIMAL ±0.010			
THREE PLACE DECIMAL ±0.005			



**BARKER PRODUCTS**  
 1310 MILLER ROAD  
 GREENVILLE, SC  
 29607

DRAWN BY: R WYMAN  
 DATE: 8/10/2017  
 MATERIAL: NOTED



1310 Miller Road  
Greenville, SC 296078

# Barker Products

*Lift Unit Specialist*

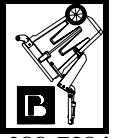

Phone:864-288-7384  
Fax:864-297-1292

## **BPH SERIES LIFT UNIT WARRANTY**

**Barker Products warranties each new dump unit to be free of defects in material and workmanship under normal use and service for a period of 1 year or 2000 hours of operation, whichever comes first, from the date of delivery.**

**This warranty excludes any obligations by BARKER PRODUCTS for the cost of down time. BARKER PRODUCTS will not warranty any dump unit which has been subject to misuse, neglect, alteration, or damaged by an accident.**

**On any work not performed by BARKER PRODUCTS or it's representative, the customer will be responsible for freight charges on all parts shipped under warranty. Parts will be invoiced at time of shipment. Defective parts must be returned to BARKER PRODUCTS within 30 days. If the part is determined to be defective the customer will be credited for the original invoice.**

**Customer warranty labor charges must be approved by BARKER PRODUCTS in advance. If not contacted for approval, BARKER PRODUCTS will not be liable for the warranty labor charge.**