



BP Lifts

By Barker Products
1310 Miller Road, Greenville, SC 29607
Phone:800-349-3149 Fax:707-371-4886



Model BPHB2-15 Series Lifts

FOR REAR LOADERS WITH LOWER LIFT BAR DUMPING COMMERCIAL CONTAINERS



- **5 Models Available**
- **Meets ANSI Z245 Type B Specifications**
- **Powered By The Dependable Smooth Acting Helical Rotary Actuator**
- **Splined Shafts To Eliminate Arm Movement And Wear**
- **EZ Bolt On Kit Standard**
- **Heavy Duty Cast Iron Bushings For Long Life Cycle**
- **36" To 45" Mounting Heights Available**
- **21" Ground Clearance**

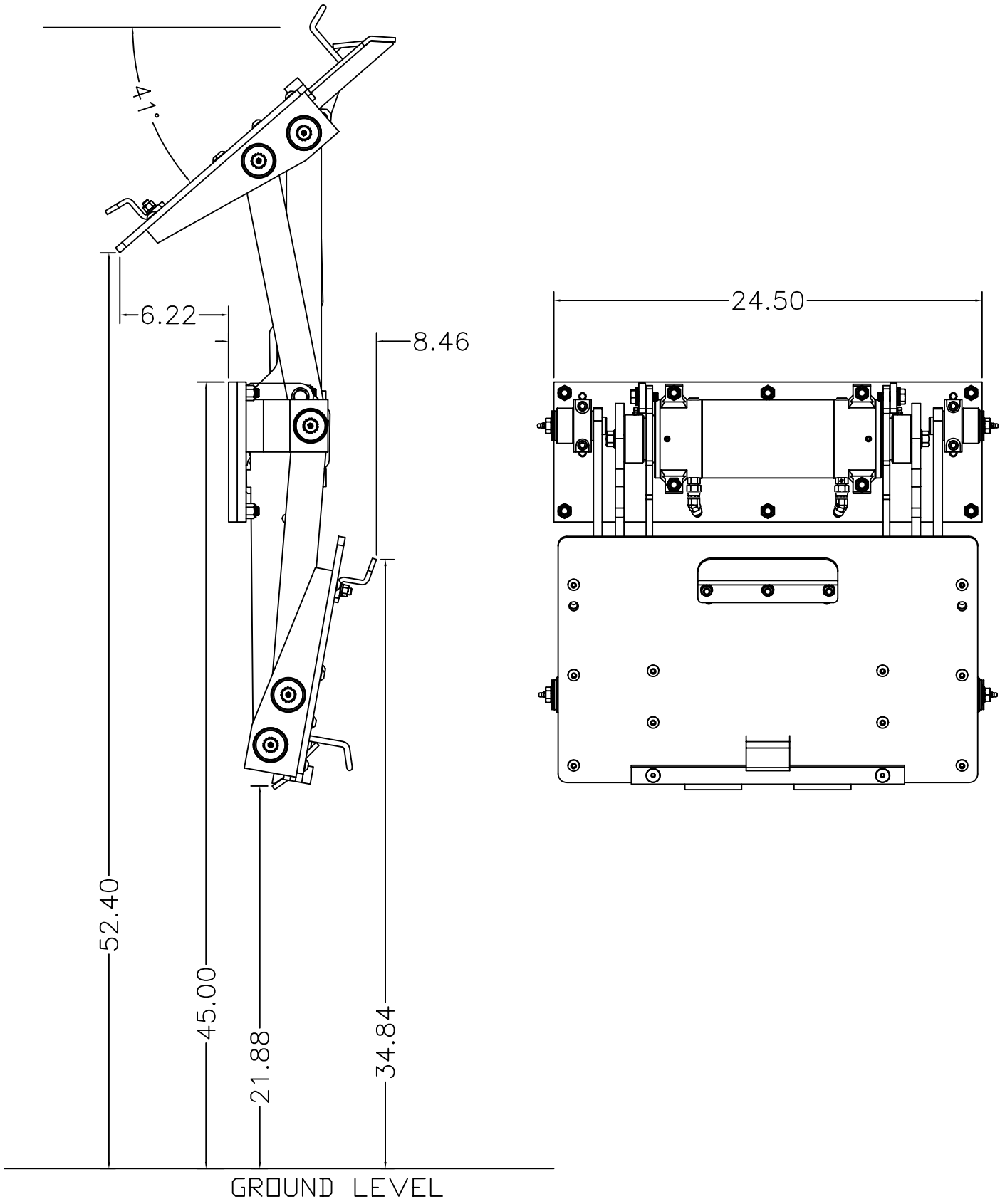

BARKER PRODUCTS
 1310 MILLER ROAD
 GREENVILLE, SC
 29607

DRAWN BY: R WYMAN
 DATE: 1/12/2022
 MATERIAL: NOTED

DO NOT SCALE DRAWING		HB2-1518 LIFT	
UNLESS OTHERWISE SPECIFIED: DIMENSIONS ARE IN INCHES			
TOLERANCES:			
FRACTIONAL ±1/32			
ANGULAR: MACH ±1° BEND ±1°			
TWO PLACE DECIMAL ±0.010			
THREE PLACE DECIMAL ±0.005			
SCALE: 1:8	WEIGHT: 231.243 #	DRAWING NO BU08400 ENVELOPE	REV 00
		SHEET 1 OF 1	

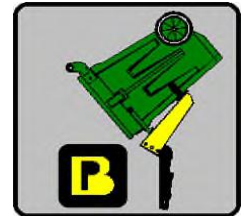
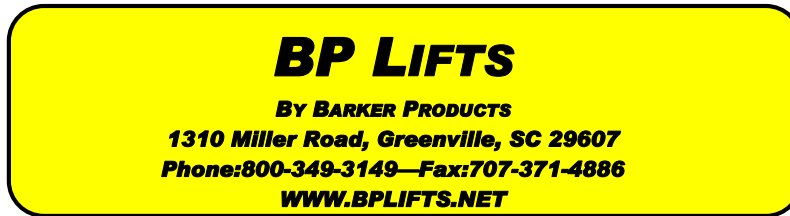

Lift Unit Installation

1. Truck must be empty, clean and parked on a level surface before installation is started.
2. Remove all bumpers and running boards that will interfere with the location of the lift units. Relocate lower mounted tail lights as needed.
3. Measure and mark the centerline of the truck hopper. The centerline of the unit or units should be a minimum of 17" from the hopper centerline.
4. Hand valves should be mounted on the side of the hopper at the most convenient height for the operator and clear of the packer controls.
5. The top of the unit mounting plate should be tack welded in place at the height recommended on the envelope dimension sheet of the unit.
CAUTION: SEE NOTE BELOW PICTURE
6. All dimensions should be approved by the customer before final welding.
7. If the mounting plate extends more than 2" above the hopper, a brace should be added.

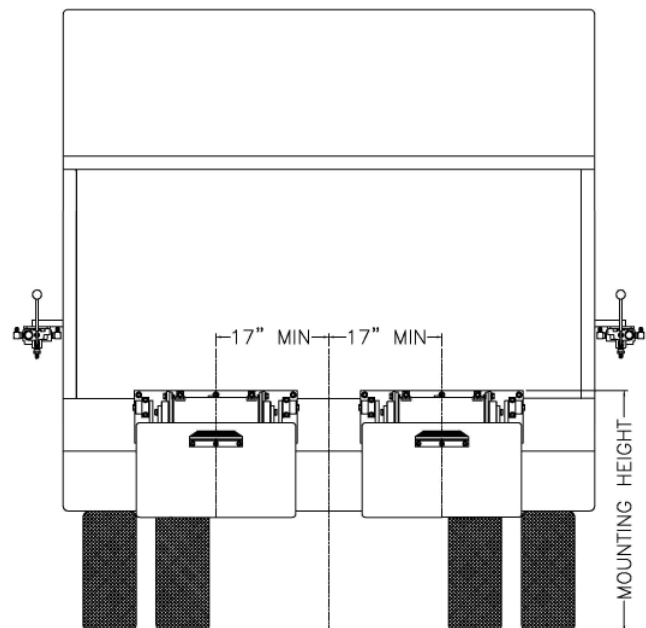

Mounting heights and locations are recommendations only. It is the responsibility of the installer to insure that the customer is satisfied with the height. Barker Products recommends that after the units are tacked in place, try the units with the can or cans the customer uses. The customer should approve your mount before final welding.



1310 Miller Road
Greenville, SC 296078

Barker Products

Lift Unit Specialist

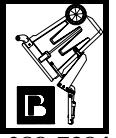

Phone:864-288-7384
Fax:864-297-1292

BPH SERIES LIFT UNIT WARRANTY

Barker Products warranties each new dump unit to be free of defects in material and workmanship under normal use and service for a period of 1 year or 2000 hours of operation, whichever comes first, from the date of delivery.

This warranty excludes any obligations by BARKER PRODUCTS for the cost of down time. BARKER PRODUCTS will not warranty any dump unit which has been subject to misuse, neglect, alteration, or damaged by an accident.

On any work not performed by BARKER PRODUCTS or it's representative, the customer will be responsible for freight charges on all parts shipped under warranty. Parts will be invoiced at time of shipment. Defective parts must be returned to BARKER PRODUCTS within 30 days. If the part is determined to be defective the customer will be credited for the original invoice.

Customer warranty labor charges must be approved by BARKER PRODUCTS in advance. If not contacted for approval, BARKER PRODUCTS will not be liable for the warranty labor charge.

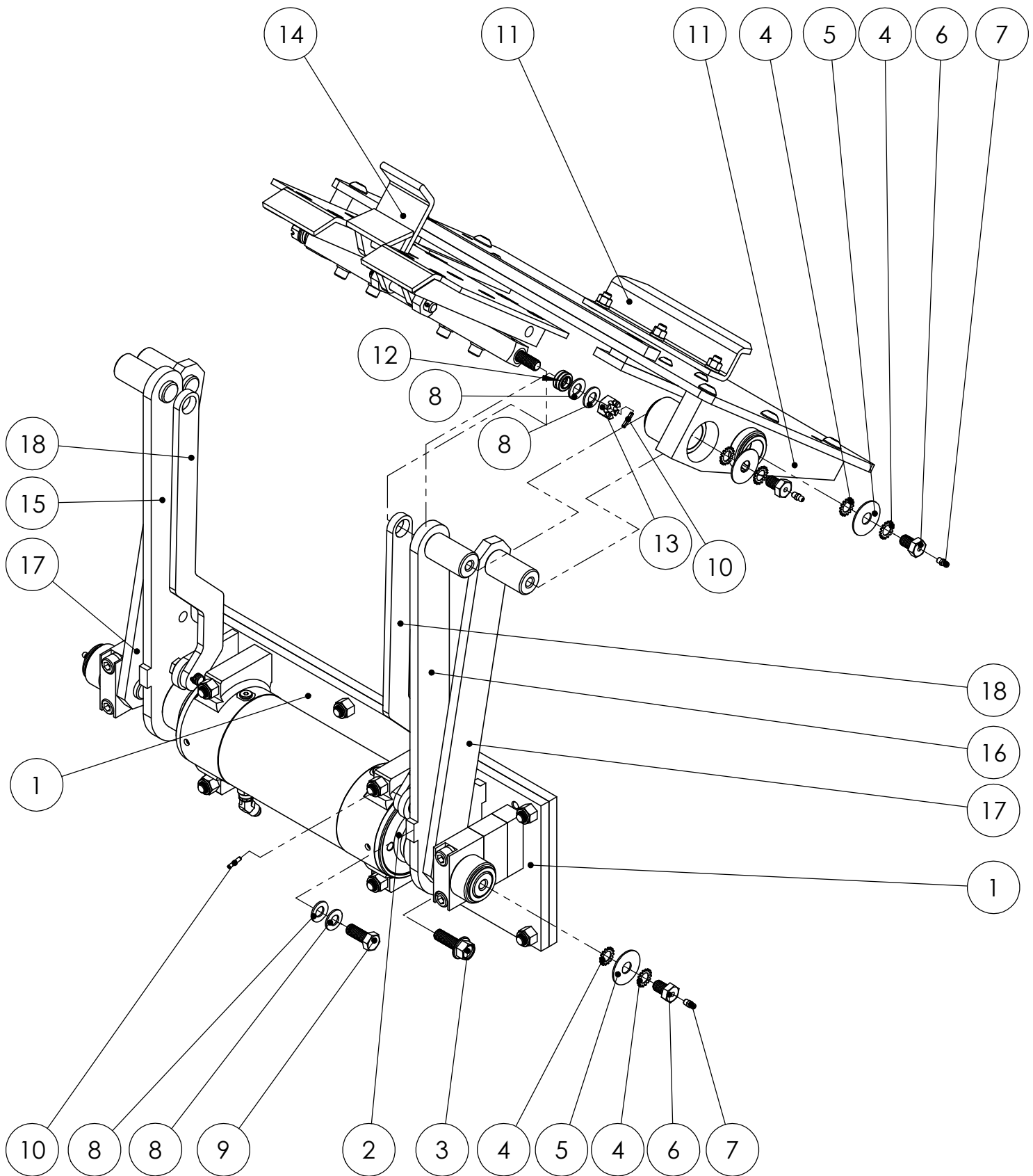

DO NOT SCALE DRAWING		HB2-1518 LIFT	
UNLESS OTHERWISE SPECIFIED: DIMENSIONS ARE IN INCHES TOLERANCES: FRACTIONAL $\pm 1/32$ ANGULAR: MACH $\pm 1^\circ$ BEND $\pm 1^\circ$ TWO PLACE DECIMAL ± 0.010 THREE PLACE DECIMAL ± 0.005		DRAWING NO BU08400	REV 00
MATERIAL: NOTED		SCALE: 1:6	WEIGHT: 228.734 # SHEET 1 OF 2



BARKER PRODUCTS
1310 MILLER ROAD
GREENVILLE, SC
29607

DRAWN BY: R WYMAN
DATE: 8/29/2017
MATERIAL: NOTED

ITEM NO.	PART NUMBER	DESCRIPTION	EXPLODED PARTS/QTY.
1	BWA10010	MAINFRAME SUB ASSY	1
2	BW07001	O-RING GREASE SEAL	2
3	XAE081312	3/8-16 X 1 1/2 FLANGED HHCS	2
4	BW02150	1/2" STAR WASHER EXTERNAL	12
5	BW07115	BEARING CAP WASHER	6
6	BW07110	BEARING CAP BOLT	6
7	BW01110	GREASE FITTING - 1/4-28 SHORT	6
8	BW02100	1/2" BELLEVILLE SPRING WASHER	8
9	BW02140	1/2-13 X 1 1/4 LOCK BOLT	2
10	BW02125	5/32 X 3/4 SPRING PIN	4
11	BWA10026	LIFT PLATE SUB ASSY	1
12	BW99308	1/2" SPHERICAL BEARING	2
13	XDE081300	1/2-13 SLOTTED NUT	2
14	BWA09990	SLIDE SUB ASSY	1
15	BW11310	LEFT LIFT ARM	1
16	BW11315	RIGHT LIFT ARM	1
17	BW10430	GUIDE ARM	2
18	BW10530	SLIDE LINK	2



BARKER PRODUCTS
1310 MILLER ROAD
GREENVILLE, SC
29607

DRAWN BY: R WYMAN

DATE: 8/29/2017

MATERIAL: NOTED

DO NOT SCALE
DRAWING

UNLESS OTHERWISE SPECIFIED:
DIMENSIONS ARE IN INCHES
TOLERANCES:
FRACTIONAL ±1/32
ANGULAR: MACH ±1° BEND ±1°
TWO PLACE DECIMAL ±0.010
THREE PLACE DECIMAL ±0.005

HB2-1518 LIFT

DRAWING NO
BU08400

REV
00

SCALE: 1:1 WEIGHT: 228.734 # SHEET 2 OF 2

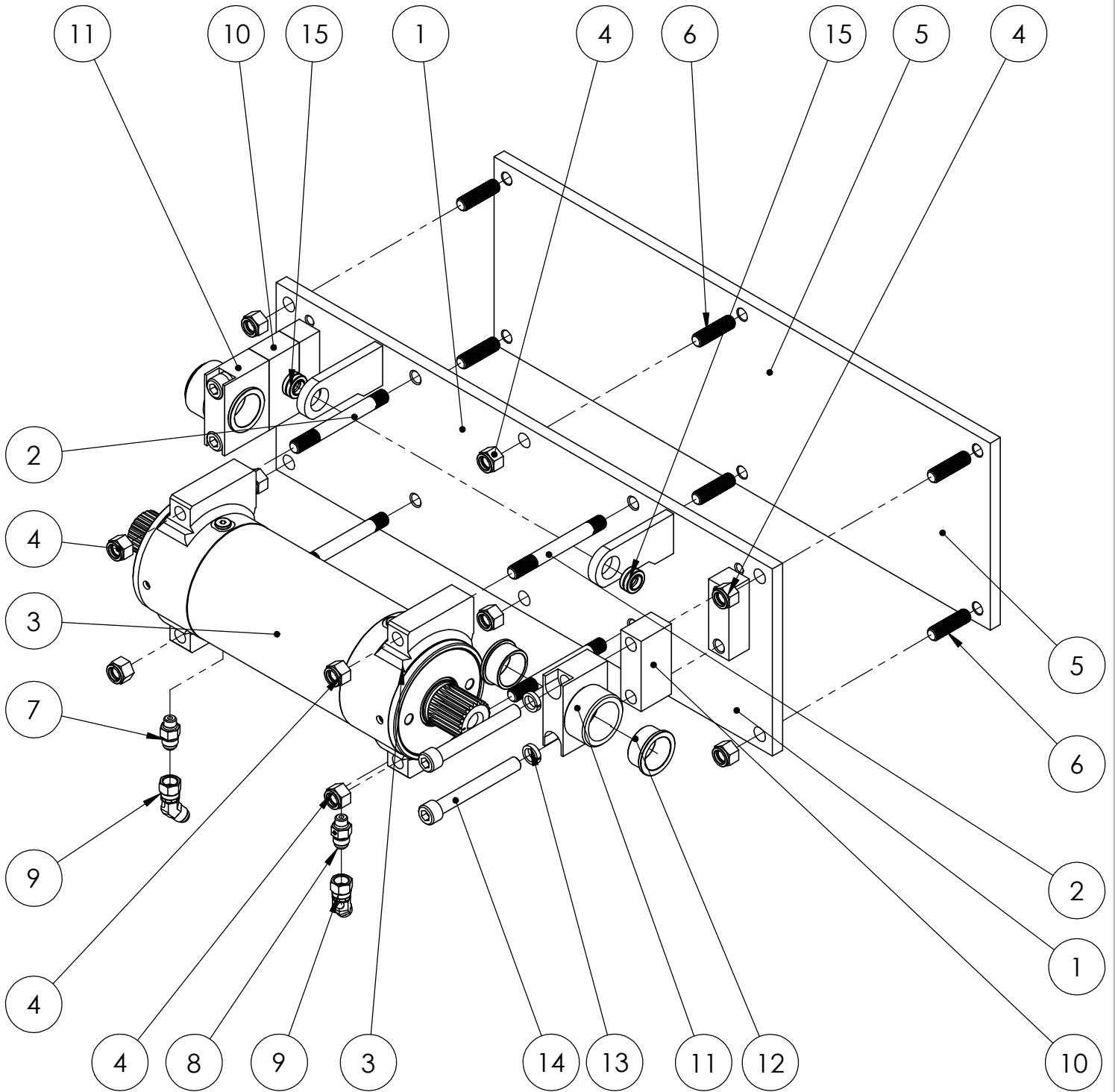

BARKER PRODUCTS
 1310 MILLER ROAD
 GREENVILLE, SC
 29607

DRAWN BY: R WYMAN
 DATE: 8/17/2017
 MATERIAL: NOTED

DO NOT SCALE
 DRAWING
 UNLESS OTHERWISE SPECIFIED:
 DIMENSIONS ARE IN INCHES
 TOLERANCES:
 FRACTIONAL $\pm 1/32$
 ANGULAR: MACH $\pm 1^\circ$ BEND $\pm 1^\circ$
 TWO PLACE DECIMAL ± 0.010
 THREE PLACE DECIMAL ± 0.005

MAINFRAME SUB ASSY PARTS
 HB2-15

DRAWING NO
 BWA10010 PARTS

REV
 00

SCALE: 1:5 WEIGHT: 114.098 # SHEET 1 OF 2

ITEM NO.	PART NUMBER	DESCRIPTION	EXPLODED PARTS/QTY.
1	BW10010	MAINFRAME	1
2	BW07125	ACTUATOR MOUNT STUD	4
3	BW07000	15K ACTUATOR	1
4	XDC082000	1/2-20 NYLOK NUT	10
5	BW07030	MOUNT PLATE H	1
6	BW07140	PLATE STUD	6
7	BV00053	093 X 6T4S ORIFICE FITTING	1
8	BR03825	6400-06-04 M TUBE X M ORING	1
9	BR04842	6502-06-06 MJ-FJS 45 DEG	2
10	BZ09016	GUIDE ARM SPACER 1 1/2	2
11	BW10080	TOP BEARING	2
12	BW00934	CAST FLANGE BUSHING	4
13	XEC0806080	1/2" HC LOCK WASHER	4
14	XAB082032	1/2-20 X 4 SHCS	4
15	BW99308	1/2" SPHERICAL BEARING	2



BARKER PRODUCTS
1310 MILLER ROAD
GREENVILLE, SC
29607

DRAWN BY: R WYMAN

DATE: 8/17/2017

MATERIAL: NOTED

DO NOT SCALE
DRAWING
UNLESS OTHERWISE SPECIFIED:
DIMENSIONS ARE IN INCHES
TOLERANCES:
FRACTIONAL ±1/32
ANGULAR: MACH ±1° BEND ±1°
TWO PLACE DECIMAL ±0.010
THREE PLACE DECIMAL ±0.005

MAINFRAME SUB ASSY PARTS
HB2-15

DRAWING NO
BWA10010 PARTS

REV
00

SCALE: 1:1 WEIGHT: 114.098 # SHEET 2 OF 2

ITEM NO.	PART NUMBER	DESCRIPTION	EXPLODED PARTS/QTY.
1	BW10026	LIFT PLATE	1
2	BW00800	SADDLE	1
3	BW00934	CAST FLANGE BUSHING	8
4	BW10170	CAN SUPPORT	1
5	BW07330	SLIDE SPACER	2
6	BW07320	SLIDE CAP	2
7	XAD061610	3/8-16 X 1 1/4 FHSCS	3
8	XAD061612	3/8-16 X 1 1/2 FSHCS	2
9	XAC061608	3/8-16 X 1 BHCS	4
10	XAC081308	1/2-13 X 1 BHCS	6
11	XEB061000	3/8 LOCKWASHER	3
12	XDA061600	3/8-16 HEX NUT	3
13	BW10030	LEFT LP MOUNT	1
14	BW10040	RIGHT LP MOUNT	1

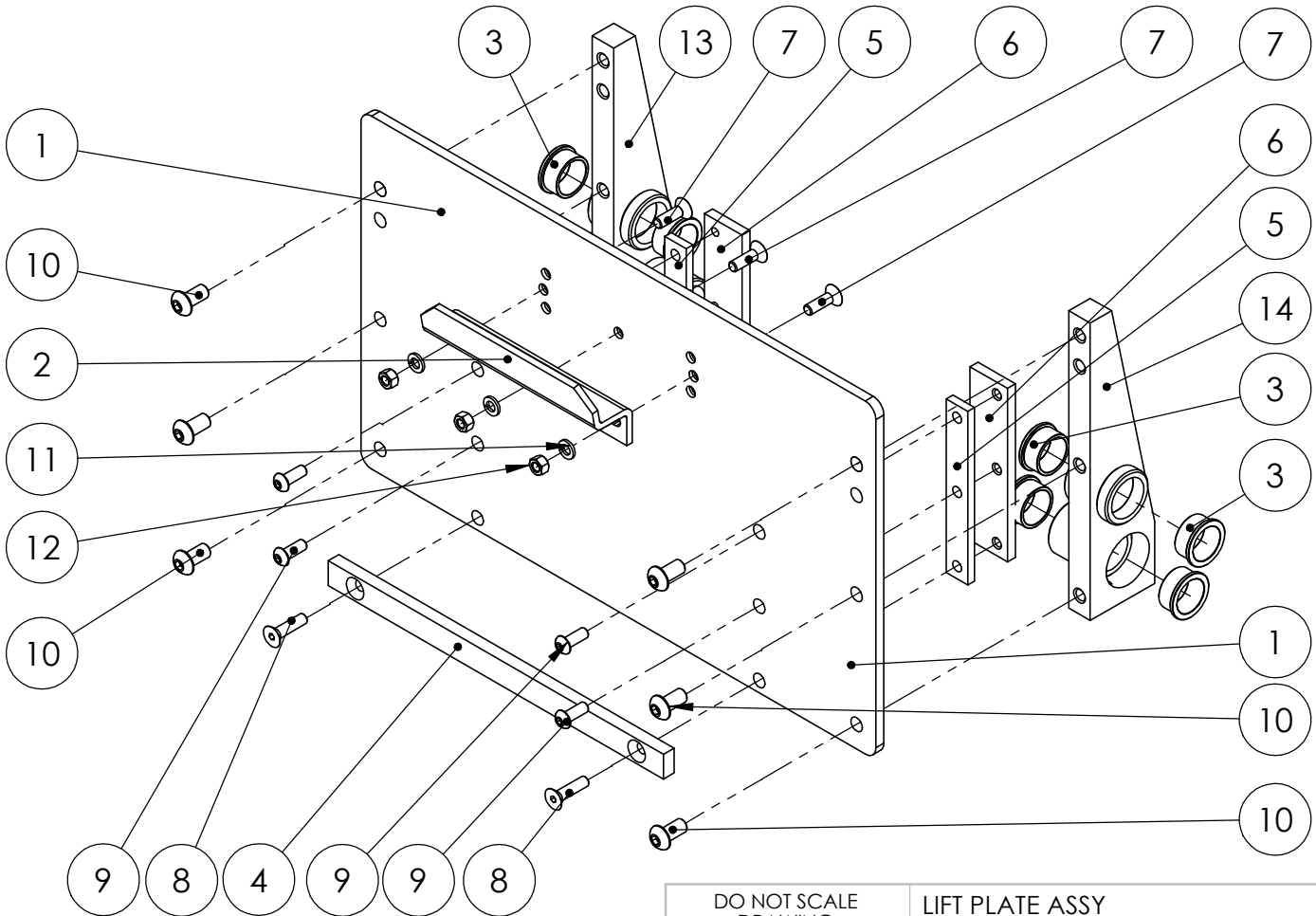

DO NOT SCALE DRAWING		LIFT PLATE ASSY HB2-15	
UNLESS OTHERWISE SPECIFIED: DIMENSIONS ARE IN INCHES TOLERANCES: FRACTIONAL ±1/32 ANGULAR: MACH ±1° BEND ±1° TWO PLACE DECIMAL ±0.010 THREE PLACE DECIMAL ±0.005		DRAWING NO BWA10026 PARTS	REV 00
MATERIAL: NOTED		SCALE: 1:6	WEIGHT: 56.988 #
		SHEET 1 OF 1	



BARKER PRODUCTS
1310 MILLER ROAD
GREENVILLE, SC
29607

DRAWN BY: R WYMAN
DATE: 8/24/2017
MATERIAL: NOTED

ITEM NO.	PART NUMBER	DESCRIPTION	EXPLODE VIEW/QTY.
1	BW10240	SLIDE SUPPORT	4
2	XAD061606	3/8-16 X 3/4 FHSCS	12
3	BW10110	SPRING SHAFT	1
3	BW10060	SLIDE DRIVE	1
5	BW10100	HOOK SHAFT	1
6	BW02125	5/32 X 3/4 SPRING PIN	4
7	BW10120	HOOK SPRING	2
8	XEB061000	3/8 LOCKWASHER	4
9	XAB061612	3/8-16 X 1 1/2 SHCS	4
10	BW10680	HOOK	1
11	BW10230	SLIDE PLATE	1

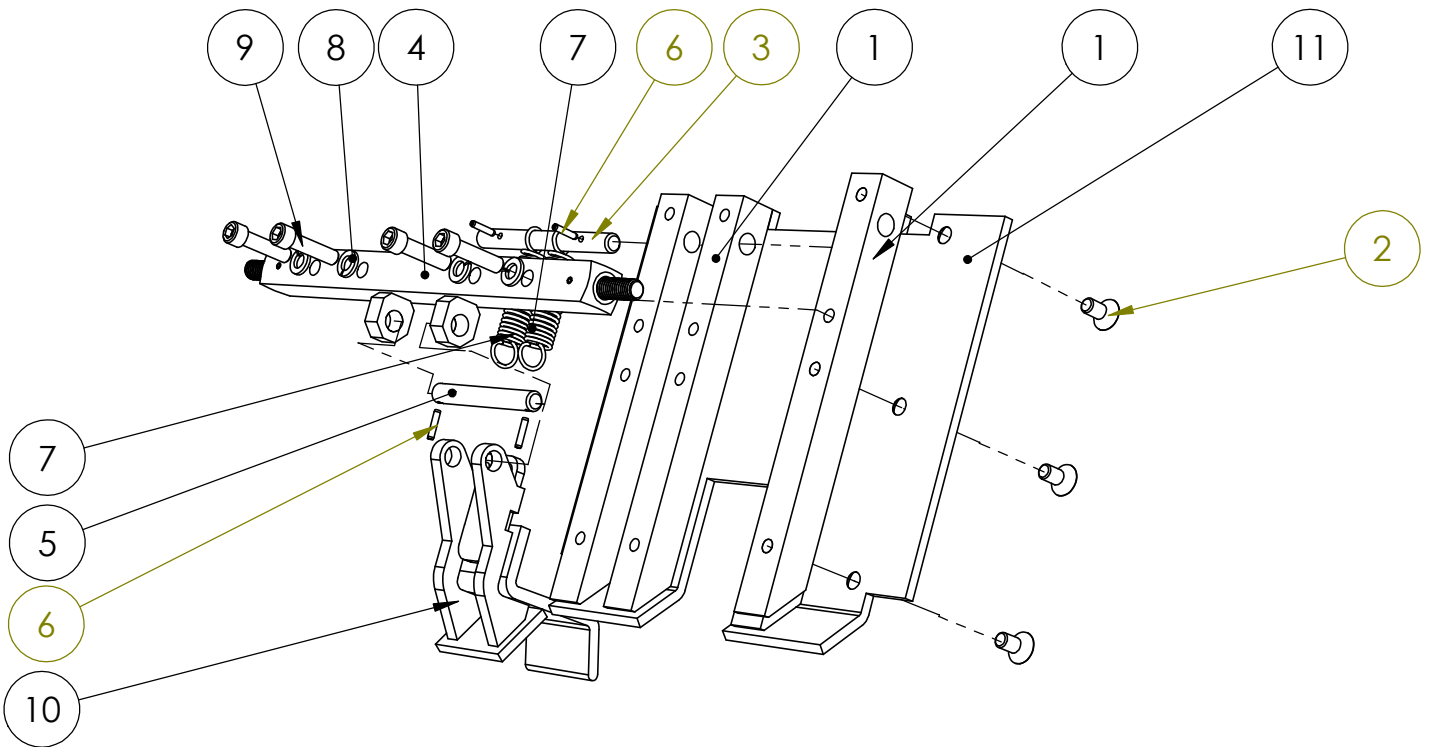

DO NOT SCALE DRAWING		SLIDE PARTS	
UNLESS OTHERWISE SPECIFIED: DIMENSIONS ARE IN INCHES TOLERANCES: FRACTIONAL ±1/32 ANGULAR: MACH ±1° BEND ±1° TWO PLACE DECIMAL ±0.010 THREE PLACE DECIMAL ±0.005		15K UNITS	
DRAWN BY: R WYMAN		DRAWING NO BWA09990	
DATE: 8/24/2017		REV 00	
MATERIAL: NOTED		SCALE: 1:4	WEIGHT: 19.600 # SHEET 1 OF 1



BARKER PRODUCTS
1310 MILLER ROAD
GREENVILLE, SC
29607