



BP Lifts

By Barker Products
1310 Miller Road, Greenville, SC 29607
Phone:800-349-3149 Fax:707-371-4886



Model BPHB2-15 Series Lifts

FOR REAR LOADERS WITH LOWER LIFT BAR DUMPING COMMERCIAL CONTAINERS



- **5 Models Available**
- **Meets ANSI Z245 Type B Specifications**
- **Powered By The Dependable Smooth Acting Helical Rotary Actuator**
- **Splined Shafts To Eliminate Arm Movement And Wear**
- **EZ Bolt On Kit Standard**
- **Heavy Duty Cast Iron Bushings For Long Life Cycle**
- **36" To 45" Mounting Heights Available**
- **21" Ground Clearance**

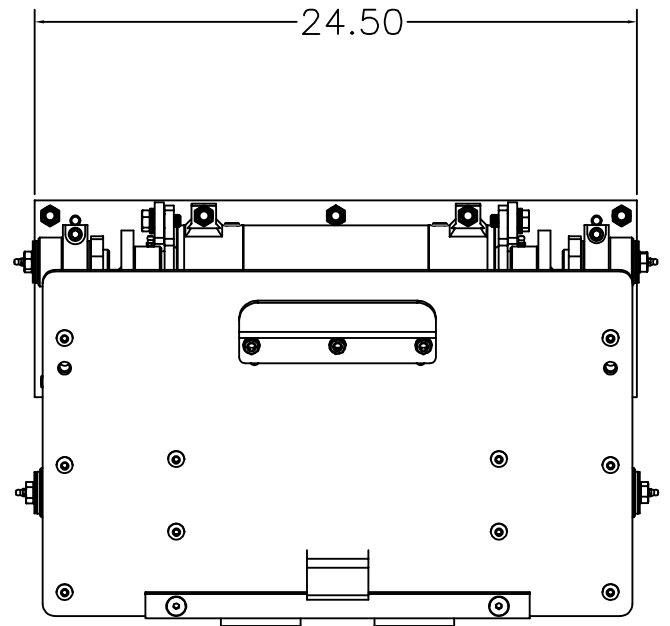
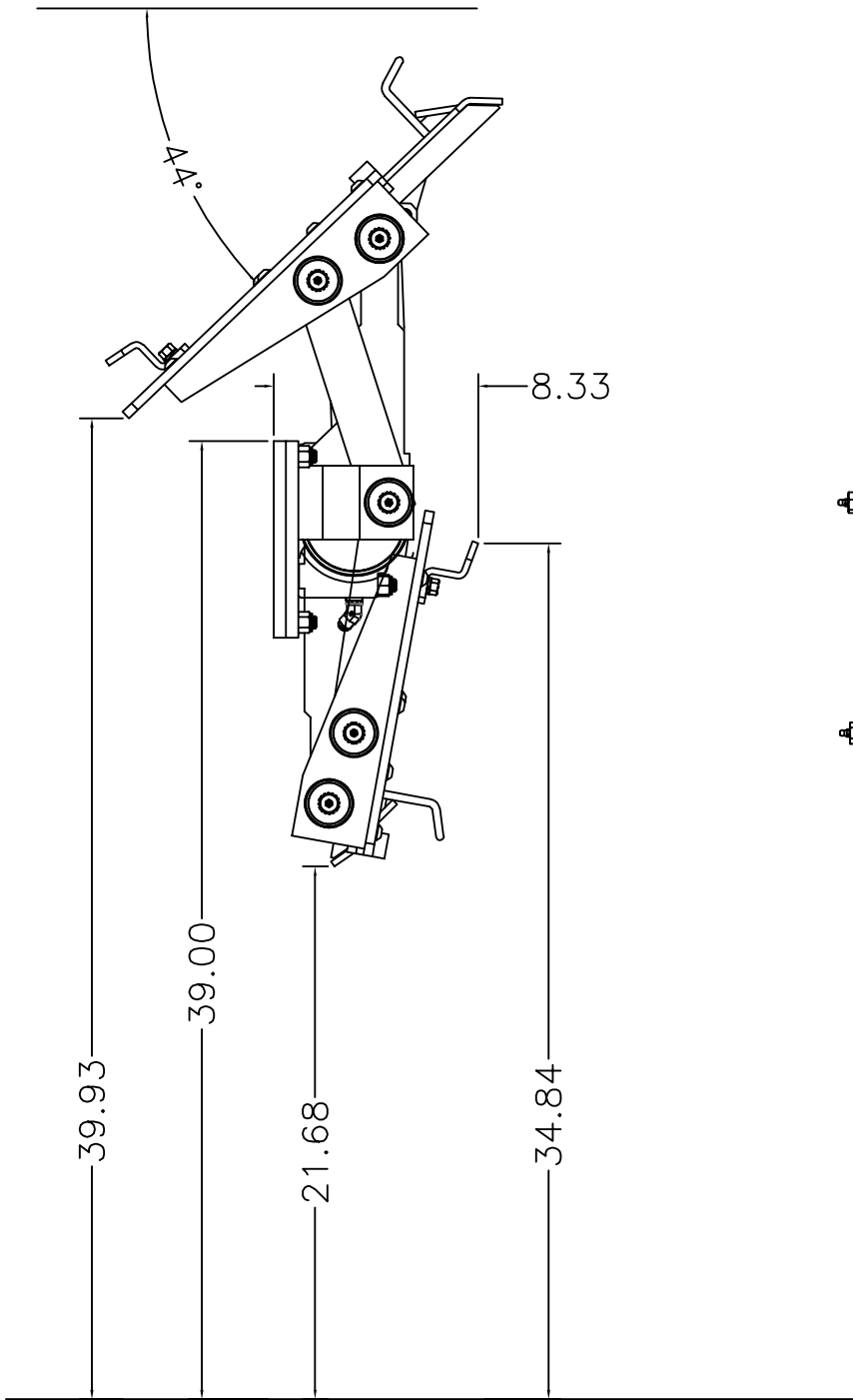

GROUND LEVEL



BARKER PRODUCTS
1310 MILLER ROAD
GREENVILLE, SC
29607

DRAWN BY: R WYMAN
DATE: 1/7/2022
MATERIAL: NOTED

DO NOT SCALE
DRAWING
UNLESS OTHERWISE SPECIFIED:
DIMENSIONS ARE IN INCHES
TOLERANCES:
FRACTIONAL ±1/32
ANGULAR: MACH ±1° BEND ±1°
TWO PLACE DECIMAL ±0.010
THREE PLACE DECIMAL ±0.005

HB2-1512 LIFT

DRAWING NO
BU08100 ENVELOPE

REV
00

SCALE: 1:8

WEIGHT: 222.222 #

SHEET 1 OF 1

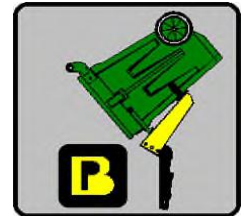
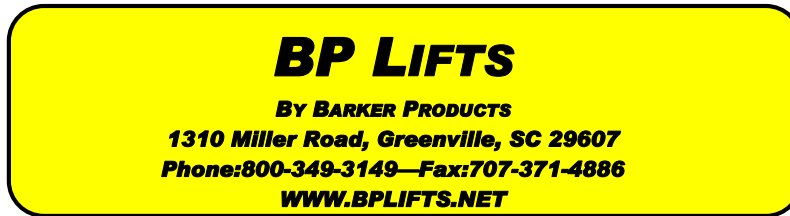

Lift Unit Installation

1. Truck must be empty, clean and parked on a level surface before installation is started.
2. Remove all bumpers and running boards that will interfere with the location of the lift units. Relocate lower mounted tail lights as needed.
3. Measure and mark the centerline of the truck hopper. The centerline of the unit or units should be a minimum of 17" from the hopper centerline.
4. Hand valves should be mounted on the side of the hopper at the most convenient height for the operator and clear of the packer controls.
5. The top of the unit mounting plate should be tack welded in place at the height recommended on the envelope dimension sheet of the unit.
CAUTION: SEE NOTE BELOW PICTURE
6. All dimensions should be approved by the customer before final welding.
7. If the mounting plate extends more than 2" above the hopper, a brace should be added.

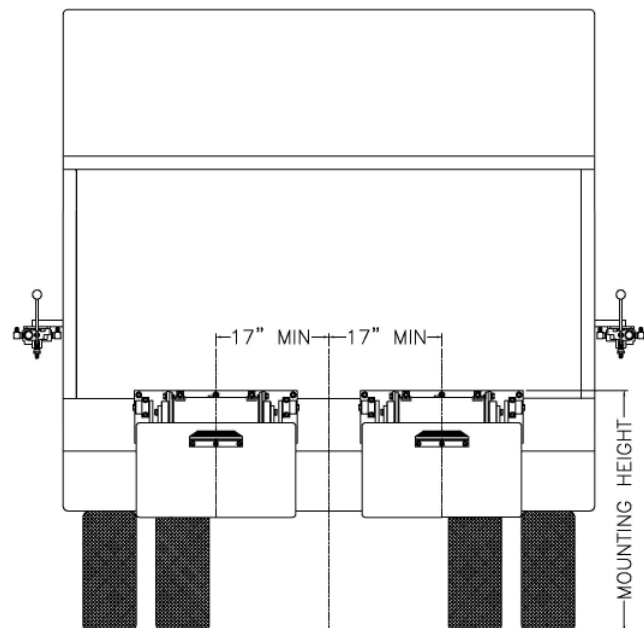

Mounting heights and locations are recommendations only. It is the responsibility of the installer to insure that the customer is satisfied with the height. Barker Products recommends that after the units are tacked in place, try the units with the can or cans the customer uses. The customer should approve your mount before final welding.



1310 Miller Road
Greenville, SC 296078

Barker Products

Lift Unit Specialist

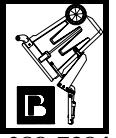

Phone:864-288-7384
Fax:864-297-1292

BPH SERIES LIFT UNIT WARRANTY

Barker Products warranties each new dump unit to be free of defects in material and workmanship under normal use and service for a period of 1 year or 2000 hours of operation, whichever comes first, from the date of delivery.

This warranty excludes any obligations by BARKER PRODUCTS for the cost of down time. BARKER PRODUCTS will not warranty any dump unit which has been subject to misuse, neglect, alteration, or damaged by an accident.

On any work not performed by BARKER PRODUCTS or it's representative, the customer will be responsible for freight charges on all parts shipped under warranty. Parts will be invoiced at time of shipment. Defective parts must be returned to BARKER PRODUCTS within 30 days. If the part is determined to be defective the customer will be credited for the original invoice.

Customer warranty labor charges must be approved by BARKER PRODUCTS in advance. If not contacted for approval, BARKER PRODUCTS will not be liable for the warranty labor charge.

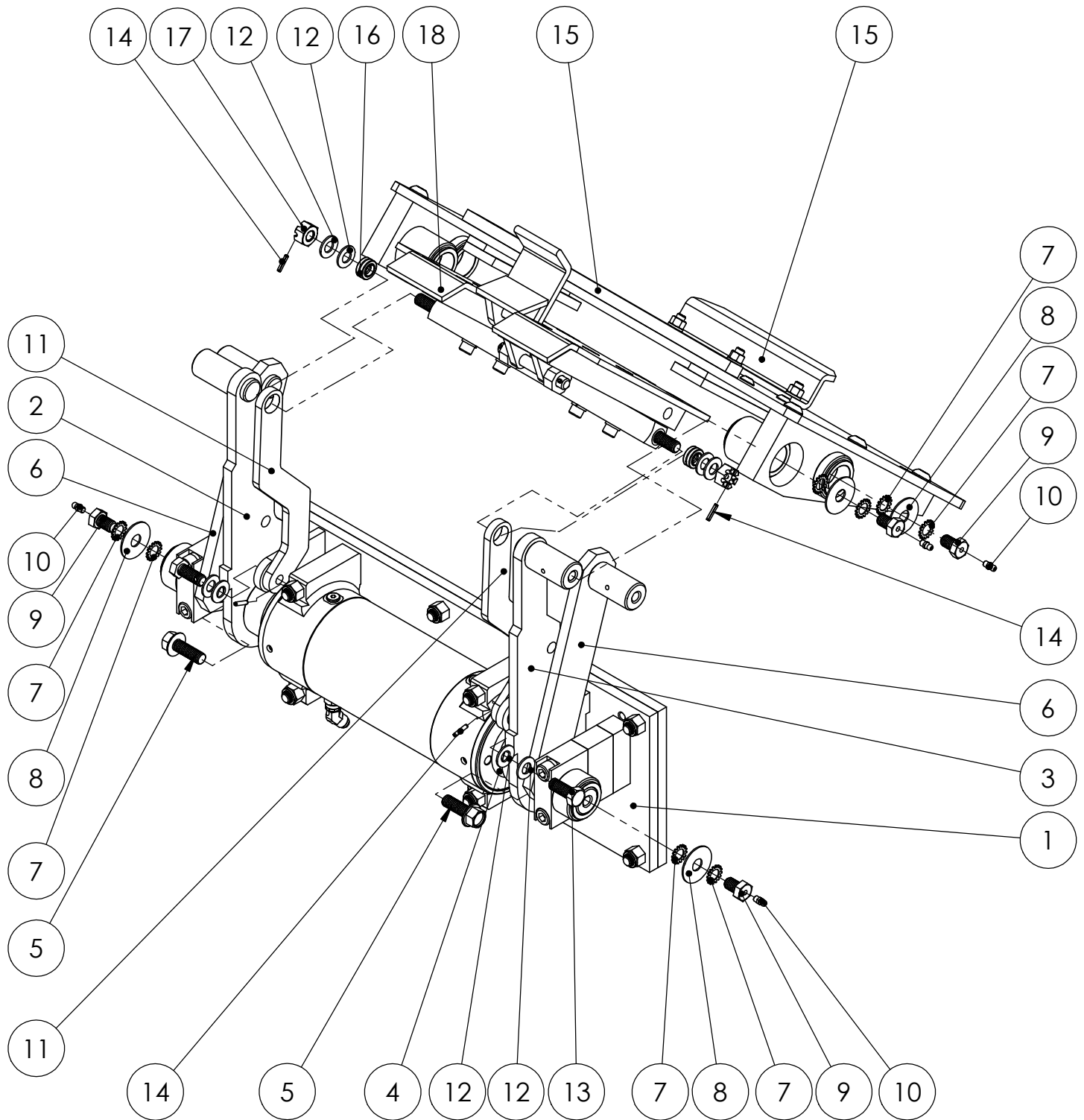

DO NOT SCALE DRAWING		HB2-1512 LIFT PARTS	
UNLESS OTHERWISE SPECIFIED: DIMENSIONS ARE IN INCHES TOLERANCES: FRACTIONAL $\pm 1/32$ ANGULAR: MACH $\pm 1^\circ$ BEND $\pm 1^\circ$ TWO PLACE DECIMAL ± 0.010 THREE PLACE DECIMAL ± 0.005		DRAWING NO	REV
		BU08100 PARTS	00
MATERIAL: NOTED	SCALE: 1:6	WEIGHT: 219.716 #	SHEET 1 OF 2



BARKER PRODUCTS
 1310 MILLER ROAD
 GREENVILLE, SC
 29607

DRAWN BY: R WYMAN
 DATE: 8/25/2017
 MATERIAL: NOTED

ITEM NO.	PART NUMBER	DESCRIPTION	EXPLODED VIEW/QTY.
1	BWA10010	MAINFRAME SUB ASSY	1
2	BW10300	LEFT LIFT ARM	1
3	BW10305	RIGHT LIFT ARM	1
4	BW07001	O-RING GREASE SEAL	2
5	XAE081312	3/8-16 X 1 1/2 FLANGED HHCS	2
6	BW10400	GUIDE ARM	2
7	BW02150	1/2" STAR WASHER EXTERNAL	12
8	BW07115	BEARING CAP WASHER	6
9	BW07110	BEARING CAP BOLT	6
10	BW01110	GREASE FITTING - 1/4-28 SHORT	6
11	BW10500	SLIDE LINK	2
12	BW02100	1/2" BELLEVILLE SPRING WASHER	8
13	BW02140	1/2-13 X 1 1/4 LOCK BOLT	2
14	BW02125	5/32 X 3/4 SPRING PIN	4
15	BWA10026	LIFT PLATE SUB ASSY	1
16	BW99308	1/2" SPHERICAL BEARING	2
17	XDE081300	1/2-13 SLOTTED NUT	2
18	BWA09990	SLIDE SUB ASSY	1



BARKER PRODUCTS
1310 MILLER ROAD
GREENVILLE, SC
29607

DRAWN BY: R WYMAN
DATE: 8/25/2017
MATERIAL: NOTED

DO NOT SCALE
DRAWING
UNLESS OTHERWISE SPECIFIED:
DIMENSIONS ARE IN INCHES
TOLERANCES:
FRACTIONAL ±1/32
ANGULAR: MACH ±1° BEND ±1°
TWO PLACE DECIMAL ±0.010
THREE PLACE DECIMAL ±0.005

HB2-1512 LIFT PARTS
DRAWING NO
BU08100 PARTS
SCALE: 1:1 WEIGHT: 219.716 # SHEET 2 OF 2
REV
00

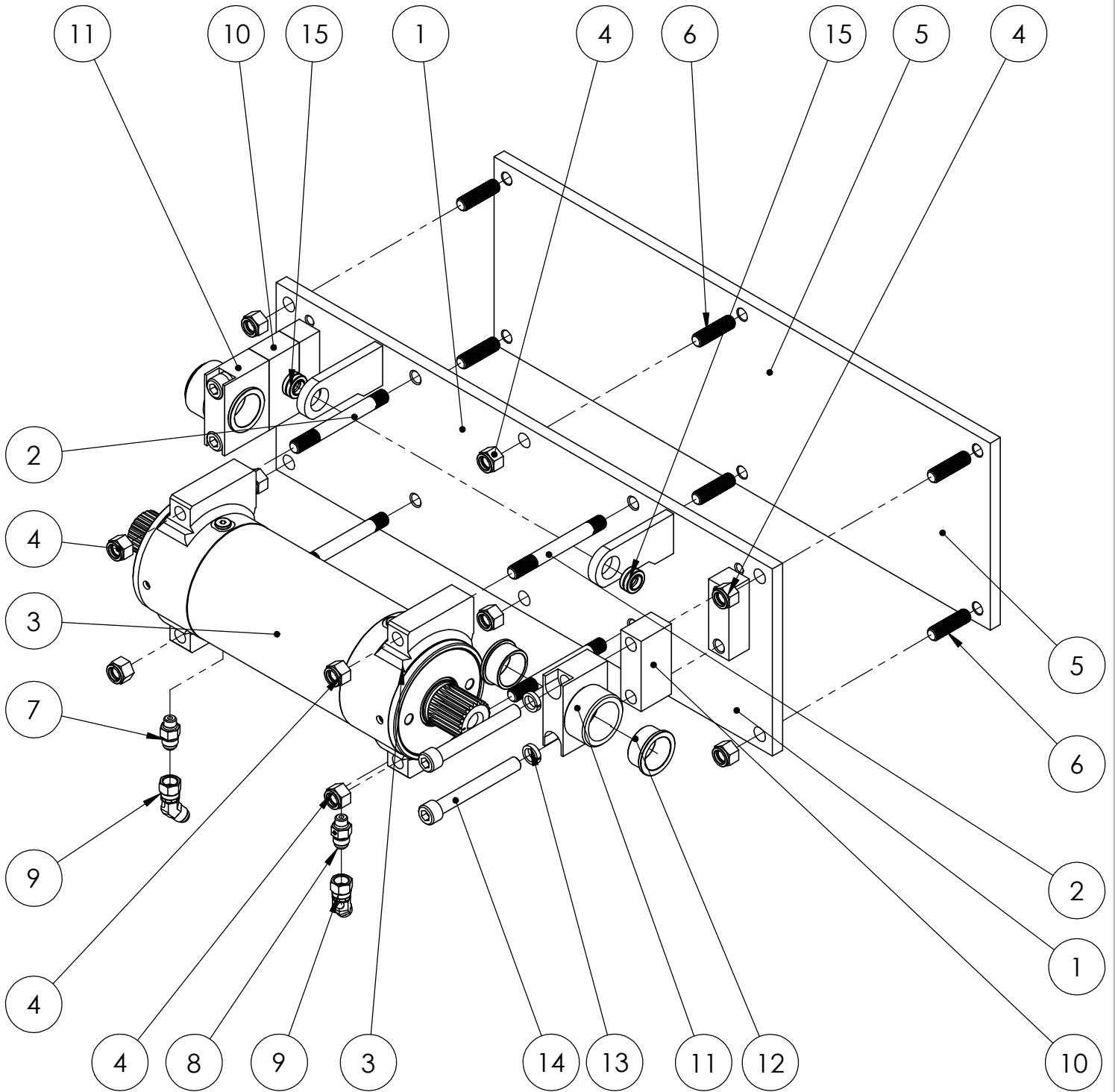

BARKER PRODUCTS
 1310 MILLER ROAD
 GREENVILLE, SC
 29607

DRAWN BY: R WYMAN
 DATE: 8/17/2017
 MATERIAL: NOTED

DO NOT SCALE
 DRAWING
 UNLESS OTHERWISE SPECIFIED:
 DIMENSIONS ARE IN INCHES
 TOLERANCES:
 FRACTIONAL $\pm 1/32$
 ANGULAR: MACH $\pm 1^\circ$ BEND $\pm 1^\circ$
 TWO PLACE DECIMAL ± 0.010
 THREE PLACE DECIMAL ± 0.005

MAINFRAME SUB ASSY PARTS
 HB2-15

DRAWING NO
 BWA10010 PARTS

REV
 00

SCALE: 1:5 WEIGHT: 114.098 # SHEET 1 OF 2

ITEM NO.	PART NUMBER	DESCRIPTION	EXPLODED PARTS/QTY.
1	BW10010	MAINFRAME	1
2	BW07125	ACTUATOR MOUNT STUD	4
3	BW07000	15K ACTUATOR	1
4	XDC082000	1/2-20 NYLOK NUT	10
5	BW07030	MOUNT PLATE H	1
6	BW07140	PLATE STUD	6
7	BV00053	093 X 6T4S ORIFICE FITTING	1
8	BR03825	6400-06-04 M TUBE X M ORING	1
9	BR04842	6502-06-06 MJ-FJS 45 DEG	2
10	BZ09016	GUIDE ARM SPACER 1 1/2	2
11	BW10080	TOP BEARING	2
12	BW00934	CAST FLANGE BUSHING	4
13	XEC0806080	1/2" HC LOCK WASHER	4
14	XAB082032	1/2-20 X 4 SHCS	4
15	BW99308	1/2" SPHERICAL BEARING	2



BARKER PRODUCTS
1310 MILLER ROAD
GREENVILLE, SC
29607

DRAWN BY: R WYMAN

DATE: 8/17/2017

MATERIAL: NOTED

DO NOT SCALE
DRAWING
UNLESS OTHERWISE SPECIFIED:
DIMENSIONS ARE IN INCHES
TOLERANCES:
FRACTIONAL ±1/32
ANGULAR: MACH ±1° BEND ±1°
TWO PLACE DECIMAL ±0.010
THREE PLACE DECIMAL ±0.005

MAINFRAME SUB ASSY PARTS
HB2-15

DRAWING NO
BWA10010 PARTS

REV
00

SCALE: 1:1 WEIGHT: 114.098 # SHEET 2 OF 2

ITEM NO.	PART NUMBER	DESCRIPTION	EXPLODED PARTS/QTY.
1	BW10026	LIFT PLATE	1
2	BW00800	SADDLE	1
3	BW00934	CAST FLANGE BUSHING	8
4	BW10170	CAN SUPPORT	1
5	BW07330	SLIDE SPACER	2
6	BW07320	SLIDE CAP	2
7	XAD061610	3/8-16 X 1 1/4 FHSCS	3
8	XAD061612	3/8-16 X 1 1/2 FSHCS	2
9	XAC061608	3/8-16 X 1 BHCS	4
10	XAC081308	1/2-13 X 1 BHCS	6
11	XEB061000	3/8 LOCKWASHER	3
12	XDA061600	3/8-16 HEX NUT	3
13	BW10030	LEFT LP MOUNT	1
14	BW10040	RIGHT LP MOUNT	1

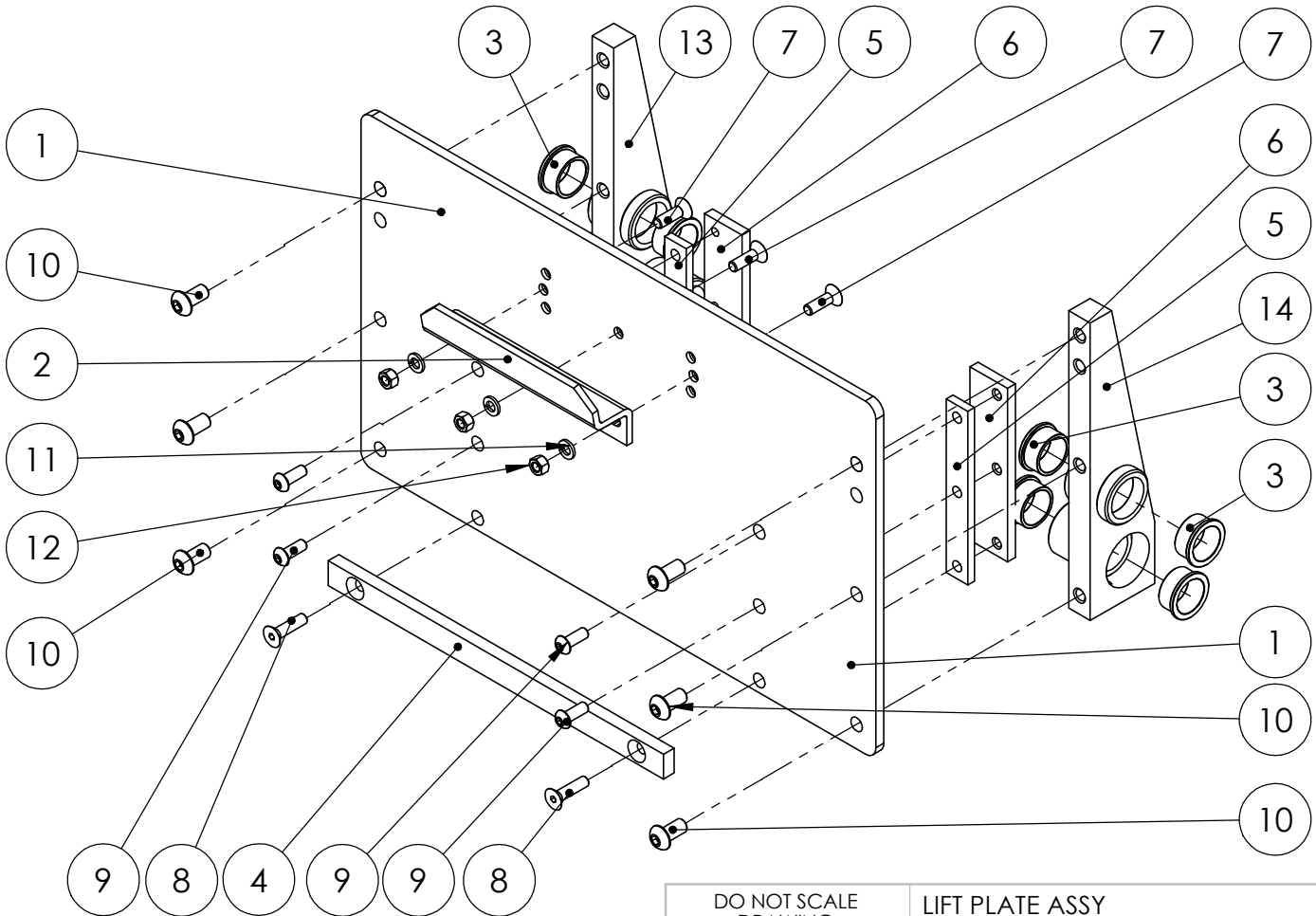

DO NOT SCALE DRAWING		LIFT PLATE ASSY HB2-15	
UNLESS OTHERWISE SPECIFIED: DIMENSIONS ARE IN INCHES TOLERANCES: FRACTIONAL ±1/32 ANGULAR: MACH ±1° BEND ±1° TWO PLACE DECIMAL ±0.010 THREE PLACE DECIMAL ±0.005		DRAWING NO BWA10026 PARTS	REV 00
MATERIAL: NOTED		SCALE: 1:6	WEIGHT: 56.988 #
		SHEET 1 OF 1	



BARKER PRODUCTS
1310 MILLER ROAD
GREENVILLE, SC
29607

DRAWN BY: R WYMAN
DATE: 8/24/2017
MATERIAL: NOTED

ITEM NO.	PART NUMBER	DESCRIPTION	EXPLODE VIEW/QTY.
1	BW10240	SLIDE SUPPORT	4
2	XAD061606	3/8-16 X 3/4 FHSCS	12
3	BW10110	SPRING SHAFT	1
3	BW10060	SLIDE DRIVE	1
5	BW10100	HOOK SHAFT	1
6	BW02125	5/32 X 3/4 SPRING PIN	4
7	BW10120	HOOK SPRING	2
8	XEB061000	3/8 LOCKWASHER	4
9	XAB061612	3/8-16 X 1 1/2 SHCS	4
10	BW10680	HOOK	1
11	BW10230	SLIDE PLATE	1

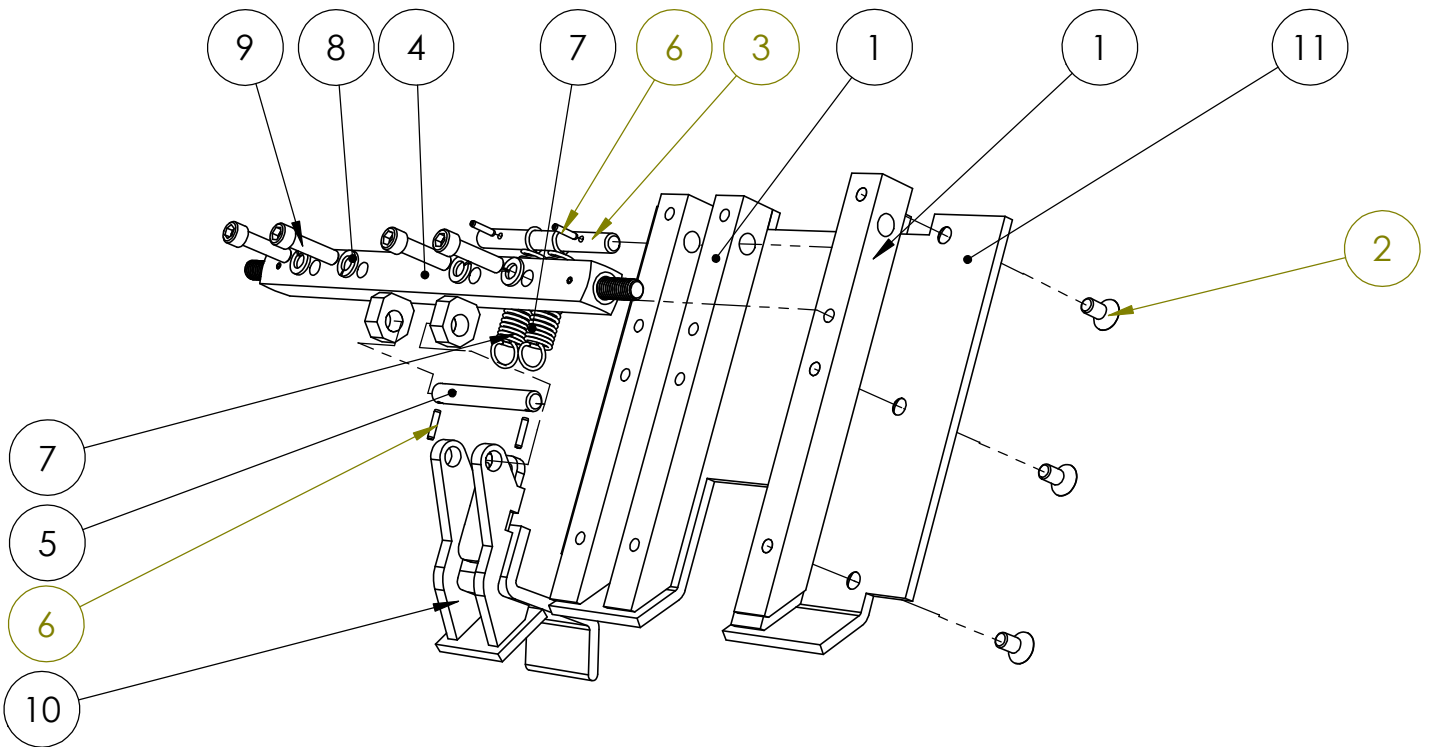

 BARKER PRODUCTS 1310 MILLER ROAD GREENVILLE, SC 29607	DRAWN BY: R WYMAN DATE: 8/24/2017 MATERIAL: NOTED	DO NOT SCALE DRAWING UNLESS OTHERWISE SPECIFIED: DIMENSIONS ARE IN INCHES TOLERANCES: FRACTIONAL ±1/32 ANGULAR: MACH ±1° BEND ±1° TWO PLACE DECIMAL ±0.010 THREE PLACE DECIMAL ±0.005	SLIDE PARTS 15K UNITS DRAWING NO BWA09990 SCALE: 1:4 WEIGHT: 19.600 #	REV 00 SHEET 1 OF 1
----------------------------------------------------------------------------------------------------------------------------------------------------------	---------------------------------------------------------	---------------------------------------------------------------------------------------------------------------------------------------------------------------------------------------------------------------	---------------------------------------------------------------------------------------------	---------------------------